



# Signature 2 Series Nitro Filter

Installation / Operation  
Manual

**General Specifications.....Page 2**

**Installation Requirements.....Page 3**

**Electrical Connection.....Page 5**

**Final Check & Annual Maintenance.....Page 7**

**Control Start-Up Procedures.....Page 7**

**Set-Up.....Page 10**

**Master Programming.....Page 11**

**Utilizing Bluetooth.....Page 12**

**Control Valve Power Assembly.....Page 13**

**Nitro Valve Body Assembly.....Page 14**

**Meter Assembly.....Page 15**

**Additional Information.....Page 17**

**Troubleshooting.....Page 19**

**Error Codes.....Page 20**

**Warranty.....Page 21**

**Register Your Product**  
Online at  
[www.csiwater.com](http://www.csiwater.com)



**CSI**  
WATER TREATMENT SYSTEMS

<b>General Specifications</b>	<b>Series</b>	
	<b>NTF15</b>	<b>NTF25</b>
Filtration (See "Filter Media) section for application	SMART BLEND™	
Filter Media Capacity (cu ft)	1.5	2.5
Mineral Tank (Vortech™)	10 X 54	13 X 54
Service Flow Rate - Continuous (gpm)	5	8
Service Flow Rate - Intermittent (gpm)	7	10
Backwash Flow Rate (gpm)	5.0	7.0
Gallons Used / Backwash	106	146
Space Required	10 X 10 X 62	13 X 13 X 62
Approximate Shipping Weight (lbs)	145	221

**WARNING**

**Lubricants**

Do NOT use Vaseline, oils, hydrocarbon lubricants or spray silicone anywhere! Petroleum base lubricants will cause swelling of o-rings and seals. The use of other lubricants may attack plastic Noryl®. It is recommended that Dow Corning® silicone grease be used as a lubricant for all control valves. Dow Corning® 7 Release Compound is used in the manufacture of Chandler Systems control valves. (Part # LT-150)

**Sealants**

Pipe dope and liquid thread sealers may contain a carrier that attacks some plastic materials. It is recommended that Teflon® tape be used to seal plastic Noryl® threaded fittings.

# SIGNATURE 2 SERIES Installation

## Installation Requirements

A level floor position ahead of piping into water heater

Unit must be installed at least 10 feet ahead of the inlet to a water heater to prevent damage due to back-up hot water.

DO NOT install the unit in an area of direct sunlight or where freezing temperatures may occur!

Locate the unit near an unswitched, 120 volt / 60 Hz grounded electrical outlet.

Check for distance and proper drain installation (e.g. floor drain, washing machine standpipe).

Determine type and size of piping required for filter connection (e.g. copper, galvanized, PVC plastic).

**Note :** If household plumbing is galvanized and you intend to make the installation with copper (or vice versa), obtain di-electric unions to prevent dissimilar metal corrosion.

**Caution :** If sweat soldering copper pipe (remember to always use lead free solder and flux), cover yoke and bypass valve with wet rags to prevent heat damage to connections and control valve. If using PVC or plastic pipe, primers and solvent cements specifically recommended for use with potable water are required.

**Note :** All plumbing lines not requiring "soft" water should be connected "upstream" of the softener, if installed. (See Typical Installation Diagrams.)

### TWO TANK SETUP

(Incoming Water from Left-Side)

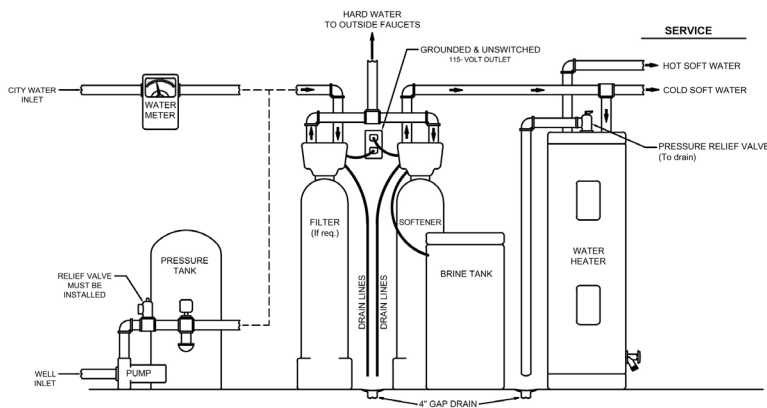

### TWO TANK SETUP

(Incoming Water from Right-Side)

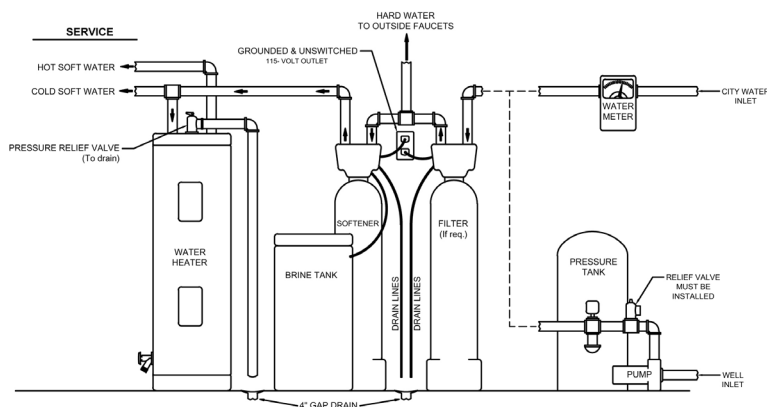

## **Installation Procedure**

### **- Water Supply Connection and Bypass Valve -**

To allow for filter servicing, swimming pool filling or lawn sprinkling, a manual Bypass Valve has been installed at the factory. The Bypass allows raw water to be manually routed around the filter.

1. Position filter at desired location for installation. If a water softener is to be installed, the filter should be positioned first and then the softener. (See Installation Diagrams.)
2. The filter material is shipped separately from the mineral tank. The tank must be loaded with material after tank has been placed at the desired location.
  - A. Remove the control valve by unscrewing from the tank.
  - B. Use cap provided to place over top of distributor tube to prevent material from entering tube while filling.
  - C. Place media funnel in hole on top of tank.
  - D. Pour several gallons of water in the tank. (Fill tank about 1/3 full.)
  - E. Pour in the required filter media. No gravel is required. The required quantity & type of media is listed in the filter specifications.
  - F. After installing filter media, add the included pack of aeration balls.
  - G. After filling the tank with material, use a garden hose or several buckets to fill the tank with water. This will permit the filtering media to become soaked while preparing the installation and will prevent the control valve from being plugged with floating material on initial backwash.
  - H. Remove funnel and clean filter media from tank threads.
  - I. Remove cap from distributor tube.
  - J. Replace control valve on mineral tank.
3. Turn OFF main water supply and OPEN nearest faucet to relieve pressure.
4. Cut main line and install appropriate elbows and extensions.

**Caution:** Raised arrows located on the sides of control valve body and bypass valve indicate proper direction of water flow. Install inlet and outlet piping in direction of arrows. It is recommended that a vacuum breaker be installed on the inlet plumbing.

### **- Drain Line Connection -**

1. Pull out clip and remove drain line assembly located on the right side of control valve. Remove drain line hose elbow and wrap threads with Teflon tape. Reinstall drain line hose elbow. Replace drain line assembly and reinstall clip.

**Caution :** Hand tighten only!

2. Install 1/2" I.D. drain line tubing (not included) from hose elbow to an open drain. A 4" gap between end of the drain line and the open drain is required to prevent waste water backflow. Keep the drain line as short as possible. An overhead drain line can be used if necessary, but should discharge below the control valve. A syphon trap (taped loop) at the outlet of the drain line is advisable to keep the drain line full and assure correct flow during backwash. Elbows or other fittings must be kept at a bare minimum.

## SIGNATURE 2 SERIES Electrical Connection

### - Electrical Connection -

1. Connect the power cord and plug power supply into a 115 volt / 60 Hz receptacle.

**Note :** Do not plug into an outlet controlled by a wall switch or pull chain that could inadvertently be turned off

### Electronic Connections

**P = Power Supply**

**B = Powered in Backwash Cycle Only**

**S = Powered in Entire Regen. Cycle**



### - Pressuring The System -

1. Move the bypass valve slowly to the Service position or open the main valve and allow water to flow to the mineral tank.
2. When the water stops flowing into the tank, open a treated water tap and allow air to be released from the lines. Allow several minutes during this time to follow steps on valve for setting the time. Once time of day is set, go back to main menu. Then close the tap. The days for backwash and air draw are already programmed.

**Note:** Anytime media (other than very fine mineral on initial startup) is apparent in the service lines, it usually indicates one of the following problems :

- A. The unit is plumbed in backward allowing the media to be carried in the service line.
  - B. The distributor tube inside the tank is not seated inside the valve or is damaged in some way.
  - C. If the media flows to the drain during backwash, after a reasonable period of soaking, check the drain line flow control to be sure that excessive water is not going to the drain allowing mineral to siphon out of the tank.
3. Hold down set/change button for five (5) seconds. (A "1" will appear), release and repeat. The unit will now enter backwash. Allow the unit to perform an entire cycle. This will rinse media and charge up the air chamber.
  4. Once unit is back in service, (approximately 60 minutes) clean water will be available. Any water used during a cycle will be untreated.

**- Final Checkout -**

1. Be certain that the bypass valve is in Service position and main valve is completely on.
2. Check electrical supply to be certain the cord is connected to an uninterrupted 115 volt outlet.
3. Be certain to REGISTER YOUR PRODUCT online at [www.csiwater.com](http://www.csiwater.com)
4. Leave this manual with the homeowner.

Important Notice - The plumbing system, piping, pressure tank, hot water tanks, softeners, etc. that have been exposed to iron bearing water may need to be cleaned of the precipitated iron that has been collected in them or iron bleed thru may be a problem. We suggest all tanks be drained and flushed thoroughly.

**- Annual Maintenance –**

Annual replacement of the seal kit is required in all single tank air systems due to air drying of the seals over time. Potential performance issues will result if this maintenance interval is not performed. Any system problems associated with this required system maintenance not being accomplished will not be covered by the factory warranty.

# SIGNATURE 2 SERIES

## Control Start-Up Procedures

### Main Menu

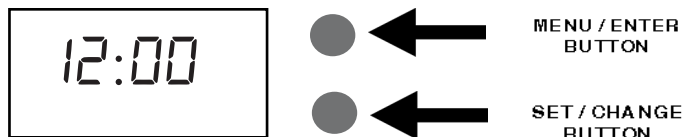

1. To enter Main Menu, press the **Menu/Enter** button.  
(Time of Day will flash)
  2. To set the **Time of Day**, press the **Set/Change** button.  
(First digit will flash) Example ( 12:00 )
    - To change digit value, press the **Set/Change** button.
    - To accept the digit value, press the **Menu/Enter** button.
    - Next digit will flash to begin setting.
    - Once the last digit display is accepted, all digits will flash.
  3. To set **A.M.** or **P.M.**, press the **Menu/Enter** button. Example ( A )
    - To change digit value, press the **Set/Change** button.
    - To accept the digit value, press the **Menu/Enter** button.
    - Once A.M. or P.M. is accepted, the next menu item will flash.
  4. Days Between Backwash
    - Press Menu / Enter Button. This display is used to set the maximum amount of time (in days) the unit can be in service without a backwash. This option setting is identified by the letter 'A' in the left digit. Backwash will begin at the set Backwash Time.  
A "0" setting will cancel this feature. The Max Value for this item is 29.  
Example: Backwash every 7 days ( A - 07 ) (Factory Setting)  
Cancel setting ( A - 00 )

To Adjust this Value Press the Set / Change Button.  
To Accept the Digit Value Press the Menu / Enter Button.
  5. To set the **Number of Days between Air Draw Cycles** (d), press the **Set/Change Button**
    - Repeat instructions from step Example ( d - 01 )

**Notes:** 1) Maximum value is 9.  
2) If value set to 0, air draw is turned off, but an air cycle will still be completed when backwash cycle occurs. If the Number of Days between Air Draw Cycles is set to a higher number of days than the Number of Days between Backwash Cycles, it will have no effect. In order to turn off all cycles, both the Days between Backwash and Days between Air Draw Cycles must be set to 0.  
3) Default setting is 1 day.
6. To Exit Main Menu, press the **Menu/Enter** button.  
**Note:** If no buttons are pressed for 60 seconds, the Main Menu will be exited automatically.



## **Normal Operation**

### **1. Home Display**



- a. Alternates between the display of Time of Day and Number of Days until the Next Backwash. (Metered Softeners will alternate between time of days and gallons remaining until next regeneration)
  - Days Remaining until the Next Backwash will count down from the entered value until it reaches 1 day remaining.
  - A Backwash Cycle will then be initiated at the next designated regeneration time.

### **2. Battery Back-Up** (Uses a standard 9-volt alkaline battery.)

#### **Features of Battery Back-Up:**

- During power failures, the battery will maintain the time of day as long as the battery has power. The display is turned off to conserve battery power during this time. To confirm that the battery is working, press either button and the display will turn on for five (5) seconds.
- If power failure occurs while system is regenerating, the Signature 2 will motor to a shut off position to prevent constant flow to drain. After power is restored, the Signature 2 will return and finish the cycle where it left off prior to the power interruption.
- When used without battery back-up, during a power failure, the unit stops at its current point in the regeneration position and then restarts at that point when the power is restored. The time will be offset by the increment of time the unit was without power, so it is necessary to reset the time of day on the unit. No other system settings will be affected.

**Starting Extra Regeneration Cycle**

1. To Start **Delayed Extra Cycle** Example [ 1 ]
  - If Days Remaining Until Next Regeneration does not read '1', press and hold the **Set/Change** button for 3 seconds until the display reads '1'
  - Regeneration cycle will initiate at the next designated regeneration time.
  
2. To start **Immediate Extra Cycle**  First complete above step.
  - Press and hold the **Set/Change** button.
  - After 3 seconds, the regeneration cycle will begin.
  
3. To **Fast Cycle** thru regeneration  First complete above 2 steps.  
 Press and hold the **Set/Change** button for 3 seconds to advance to the next cycle step.  
**Note:** Fast Cycle is not necessary unless desired to manually step through each cycle step.  
 (Repeat until valve returns to the home display)

**Regeneration Cycle**

Nitro	Default Cycle Step Times	Minutes
Step 1	Air Release (non-adjustable)	6
Step 2	Backwash	10
Step 3	Rest	5
Step 4	Air Replenish	20
Step 5	Rapid Rinse	5

**Note:** Depending upon system pressure and other factors, it is possible to observe flow to drain in the rest cycle.

- When the valve is between positions, the display will flash the number of the step it is moving towards.
- The default time at which regeneration will occur is 12:00 a.m.

The motor's run direction during a particular regeneration cycle step is indicated by the rotation direction of the last 2 digit displays.

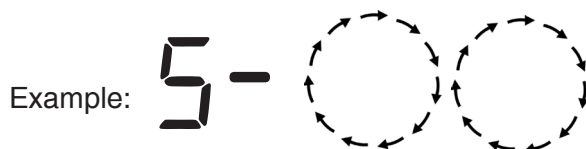

## Nitro Only Backwash Cycle Step Explanation

- Step 1:** Air Release Step  
For approximately 6 minute  
-Non-adjustable
- Step 2:** Backwash Step  
- Default of 10 minutes
- Step 3:** Rest Step  
- Default of 5 minutes
- Step 4:** Air Replenish Step  
- Default of 20 minutes

**Example:** Valve replenish step with 20 minutes remaining

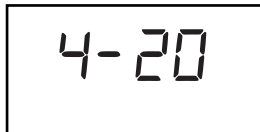

- Step 5:** Rapid Rinse Step  
- Default of 5 minutes

## Master Programming Mode

To enter Master Programming Mode, press and hold both buttons for 5 seconds.

Note: All Master Programming functions have been preset at the factory. Unless a change is desired, it is **NOT** necessary to enter Master Programming Mode.

1. **Regeneration Time (r)** Example (r 12P)
- The time of day at which regeneration may take place is designated by the letter "r".
  - Default regeneration time setting is 12P
  - The first display digit indicates A.M. or P. M. To change the value, press the **Set/Change** button.
  - Press **Menu/Enter** button to accept the value and move to the next digit.
  - The second and third display digits indicate the hour at which the regeneration will occur.
  - Change the digits with the **Set/Change** button and accept with the **Menu/Enter** button.
  - After the entire display flashes, press the **Menu/Enter** button to move to the next menu item.

## SIGNATURE 2 SERIES Master Programming Mode

### 2. Backwash Cycle Step Times\* Nitro (Steps 2, 3, 4, 5)

Example ( 3 - 20 )

- The next 4 displays set the duration of time in minutes for each backwash cycle step.
- The step number which is currently modifiable is indicated on the far left of the display screen.
- The number of minutes allotted for the selected backwash step is displayed on the far right.
- Change the digit values using the **Set/Change** and **Menu/Enter** buttons as described above.

#### Note on Air Draw Cycle (4): Nitro Filter

The longer the unit is set to remain in the Air Draw cycle (4), the more air is drawn into the system. A default setting of 20 minutes draws air down to the level of a normal media bed height. If the system needs more air, increase the time setting for step (4) or decrease the number of days between air draw cycles.

### 3. Bluetooth Enabled

bE I (ON)

bE □ (OFF)

### 4. Bluetooth Password

bLPP is displayed for one second, then password is displayed.

- To change digit value, press the **Set/Change** button. Example ( R)
- To accept the digit value, press the **Menu/Enter** button.
- Next digit will flash to begin setting
- Once the last digit display is accepted, all digits will flash.

5. To Exit the Master Programming Mode, press the **Menu/Enter** button until time of day returns.

**Note:** If no buttons are pressed for 60 seconds, the Master Programming Mode will be exited automatically.

To take advantage of the Bluetooth interface this feature must be set up on a compatible Bluetooth enabled smart phones or tablets.

**Note:** Valves with a revision number greater or equal to “C2.00” are only compatible with Bluetooth 4.0+ (a.k.a. Bluetooth LE) Smartphones and tablets. If you have an Android or Apple device with a compatible Bluetooth radio it can be used to connect to the valve. Valves with a revision number less than “C2.00” are only compatible with Android devices and these valves use a Bluetooth 2.0 radio. In the rest of this section valves with a revision number greater or equal to “C2.00” will be referred to as BTLE, valves with a revision number less than “C2.00” will be referred to as BT.

(The firmware revision of the valve can be viewed on the valve display for 2 seconds after the valve is powered up.)

Unfortunately due to changing Bluetooth and Tablet / Phone manufacturing standards, not all tablets and smart phones are compatible with all valve versions. In general, the below table should guide you in compatibility.

	BT Legacy View Valve	BTLE Legacy View Valve
Android Device with BT 4.0+	Yes	Yes
Android Device with older BT	Yes	No
Apple Device with BT 4.0+	No	Yes

1. Download and install the Legacy View app from the Google Play Store, Apple App Store or [www.ChandlerSystemsInc.com](http://www.ChandlerSystemsInc.com)
2. If your valve revision is a BTLE valve you can skip this step. Otherwise, if it is a BT valve the following steps must be followed to pair your smart phone or tablet to the control valve.
  - Open the settings menu on your smart phone or tablet and click on Bluetooth.
  - Look for the softener or filter valve you want to connect to under the list of available Bluetooth devices.
  - Select the device and pair (Default password is: 1234)
3. Open the Legacy View app
  - Choose a valve device at any time from the list of available devices to connect to by clicking on it.
  - If the valve you want to connect to doesn't show up, or there is a problem connecting to a device you can press the “Scan for Devices” button or the Legacy View logo at any time to refresh the list and start the process over.
  - If the valve device is a BTLE valve and it has a password other than the default password, the first time you connect to it the app will ask you to enter the password. After entering it the first time you should not need to enter it again unless it changes.
4. BTLE Valve devices can be updated by the App. When the app is updated from the Google Play Store or the Apple App Store, it may contain an updated firmware program for the valve devices. These updates could contain new features or operational improvements. It is up to the user to allow these updates to be sent to the valve device.

Uploading a new program takes approximately 1 minute.



FCC ID: SWPLV-019 or SWPEV-019-BLE  
 Name of Grantee: CHANDLER SYSTEMS, INC.  
 Equipment Class: Part 15 Low Power Communication Device  
 Notes: Legacy View Valve

This device complies with part 15 of the FCC Rules. Operation is subject to the following conditions: (1) this device may not cause harmful interference, and (2) this device must accept any interference received, including interference that may cause undesired operation. Changes or modifications not expressly approved by the party responsible for compliance could void the user's authority to operate the equipment. NOTE: This equipment has been tested and found to comply with the limits for a Class B digital device, pursuant to Part 15 of the FCC Rules. These limits are designed to provide reasonable protection against harmful interference in a residential installation. This equipment generates, uses and can radiate radio frequency energy and, if not installed and used in accordance with the instructions, may cause harmful interference to radio communications. However, there is no guarantee that interference will not occur in a particular installation. If this equipment does cause harmful interference to radio or television reception, which can be determined by turning the equipment off and on, the user is encouraged to try to correct the interference by one or more of the following measures:

- Reorient or relocate the receiving antenna.
- Increase the separation between the equipment and receiver.
- Connect the equipment into an outlet on a circuit different from that to which the receiver is connected.
- Consult the dealer or an experienced radio/TV technician for help.

# SIGNATURE 2 SERIES Control Valve Powerhead Assembly (Nitro)

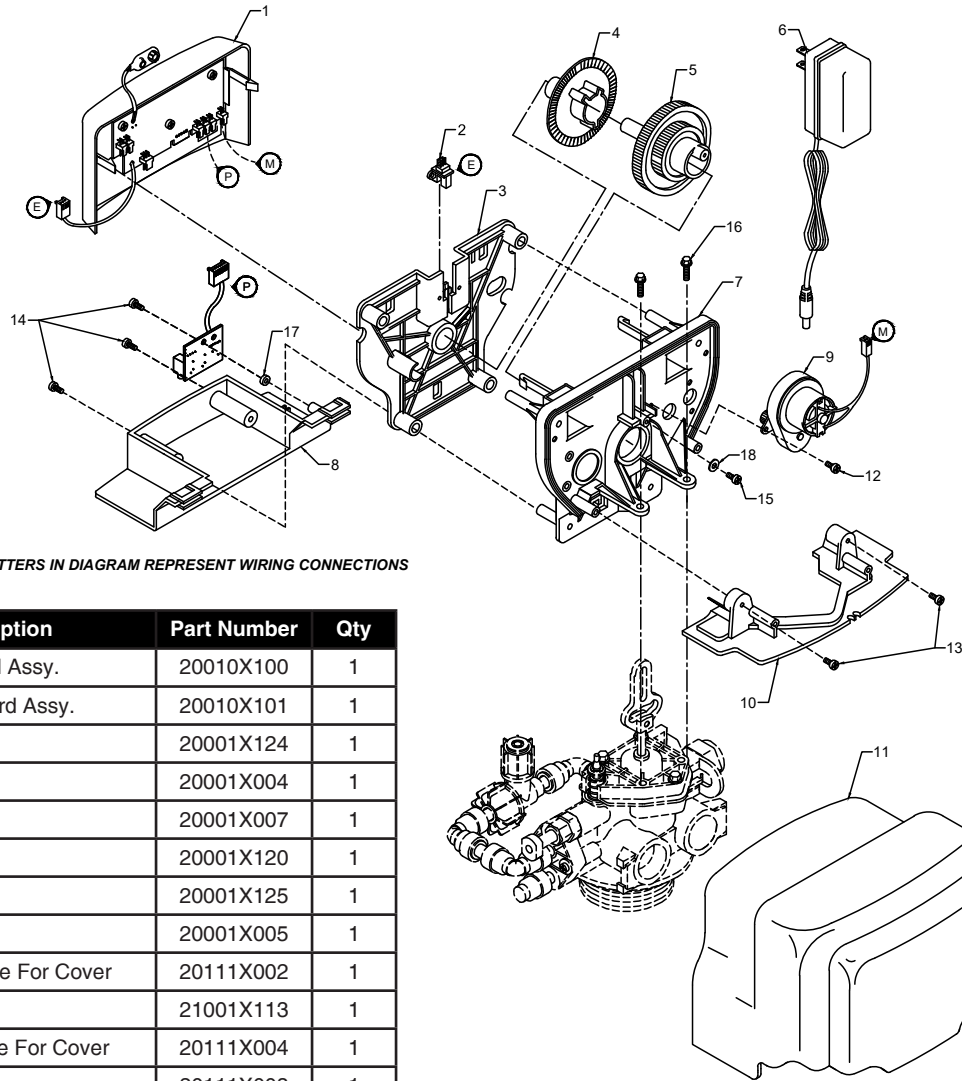

LETTERS IN DIAGRAM REPRESENT WIRING CONNECTIONS

Ref	Description	Part Number	Qty
0	Nitro Powerhead Assy.	20010X100	1
1	Nitro Circuit Board Assy.	20010X101	1
2	Encoder	20001X124	1
3	Front Plate	20001X004	1
4	Encoder Wheel	20001X007	1
5	Main Gear	20001X120	1
6	Power Supply	20001X125	1
7	Back Plate	20001X005	1
8	Lower Front Base For Cover	20111X002	1
9	Motor	21001X113	1
10	Lower Back Base For Cover	20111X004	1
11	Slide Cover	20111X003	1
12	Motor Screw	SC2	4
13	Screw	SC9	3
14	Screw	SC10	3
15	Piston Screw	20001X007	1
16	Valve Hex Screw	20001X001	2
17	Circuit Board Washer	20111X014	1
18	Piston Washer	20001X002	1

# SIGNATURE 2 SERIES Nitro Valve Body Assembly

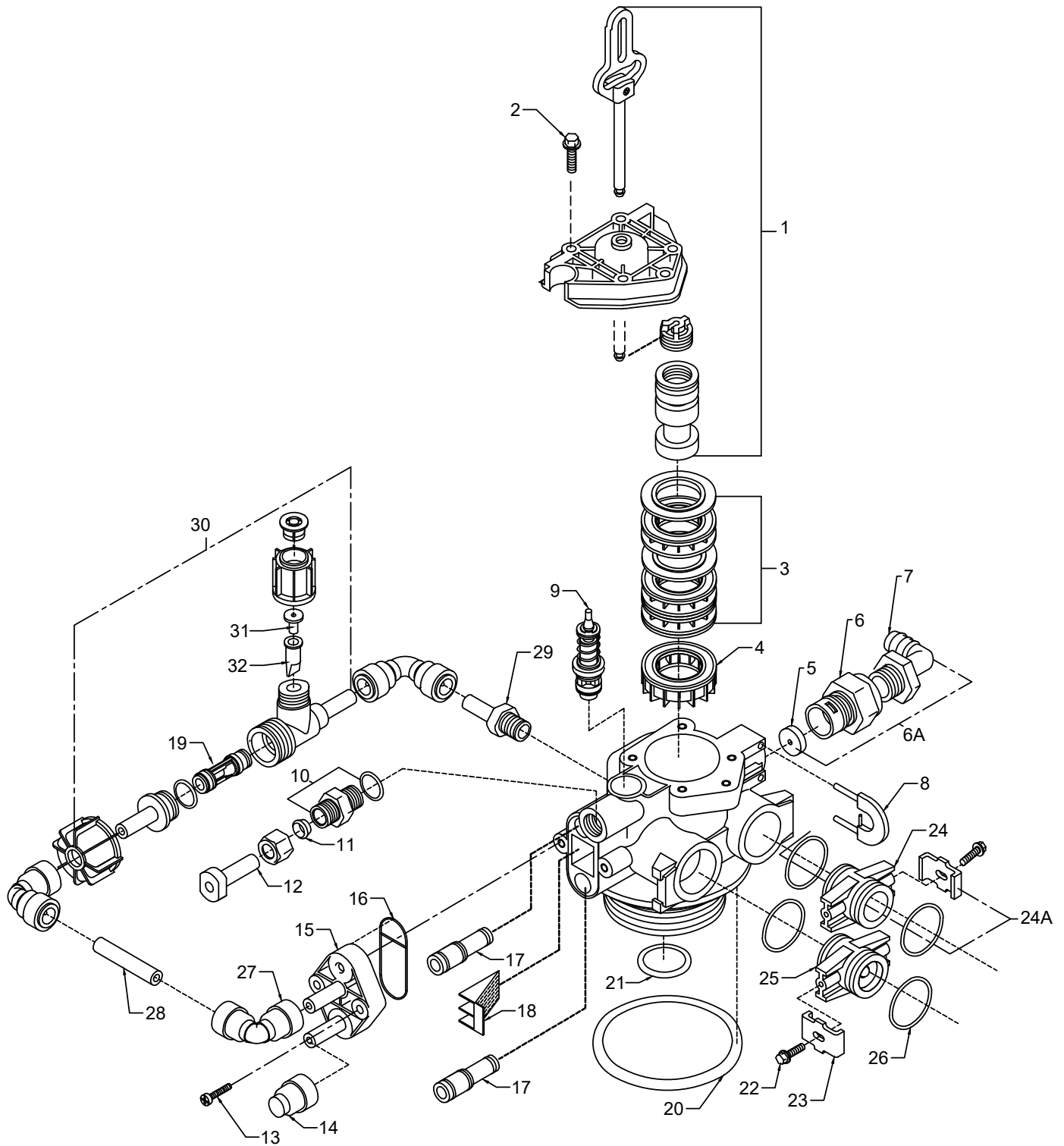

**SIGNATURE 2 SERIES**  
**Nitro Valve Body Assembly**

<b>Ref</b>	<b>Description</b>	<b>Part No.</b>	<b>Qty</b>
1	Piston Assembly	20009X231	1
2	10-24 X 13/16 Hex Head	20001X226	3
3	Seal and Spacer Kit	20561X253	1
4	End Spacer	N/A	1
5a	DLFC 5.0 Button	20251X272	1
	DLFC 7.0 Button	20251X273	1
6a	Flow Control Assembly 5.0	20251X262	1
	Flow Control Assembly 7.0	20251X264	1
6	Drain Line Flow Control Housing	20251X100	1
7	Drain Line Hose Barb	20251X255	1
8	Drain Retainer Clip	20001X214	1
9	Brine Valve	20009X225	1
10	Brine Line Flow Control Assy. Stainless Steel	20009X228	1
11	Brine Line Ferrule	20251X305	1
12	Plug	20009X005	1
13	10-24 X 1 Hex Screw	20001X226	2
14	Injector Cap Plug	20009X010	1
15	Injector Cover Nitro	20009X001	1
16	Injector Seal	20001X224	1
17	Injector Plug	20001X217	2
18	Injector Screen	20001X222	1
19	Injector	20001X219	1
20	Tank O-Ring	20001X215	1
21	Distributor Pilot O-Ring	20561X204	1
22	8-18 X 5/8" Hex Screw	20561X217	2
23	Clip	20561X201	2
24	Adapter Coupling	20561X215	1
25	Adapter Coupling Checkvalve	20111X011	1
26	Adapter O-Ring	20561X216	4
27	3/8" 90 Elbow	GA-T0620666B	3
28	3/8" Black Tubing/ FT.	57005X001	1
29	Stem Adapter	GA-S0660416B	1
30	Injection Assembly	20009X007	1
31	Duckbill Retainer	20009X016	1
32	Duckbill	20009X022	1



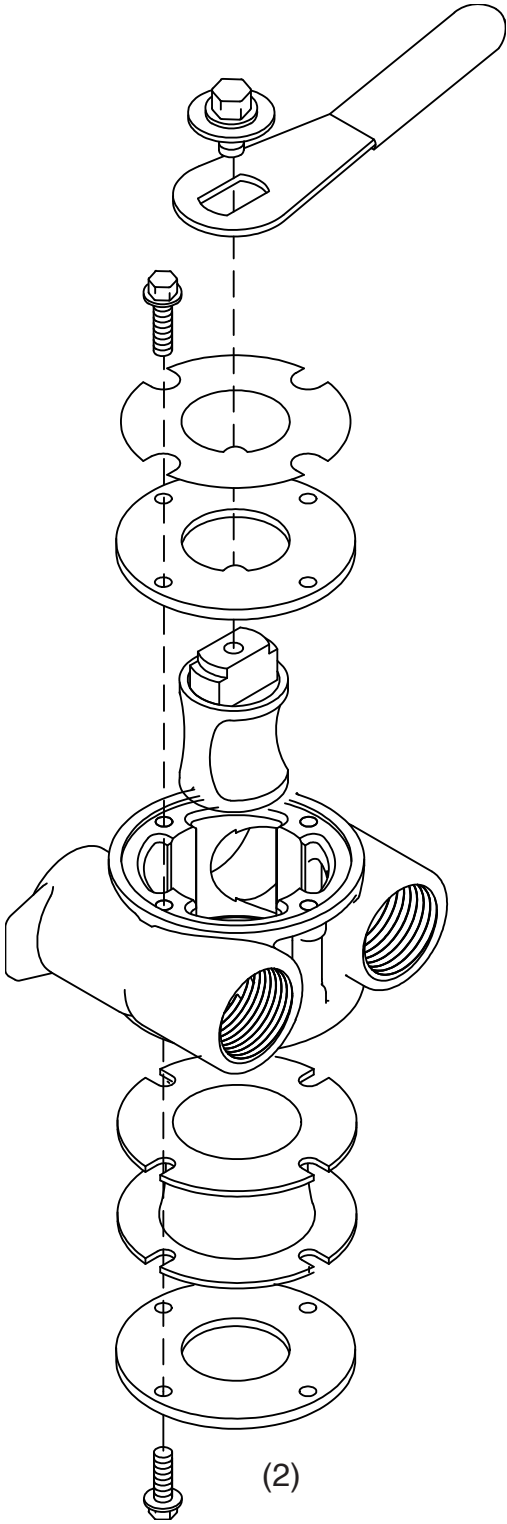
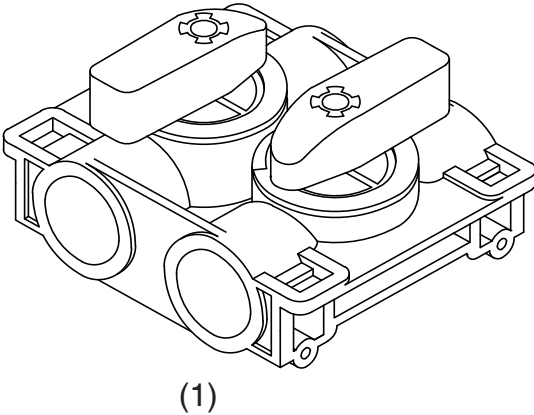

Ref #	Description	Part #	Qty
1	Plastic Bypass Valve Assembly	20561X292	1
2	Bypass Valve 3/4" Stainless Steel	20561X270	1
	Bypass Valve 1" Stainless Steel	20561X283	1

### A. General Preliminary Instructions

#### PERFORM BEFORE ALL SERVICING OPERATIONS

1. Turn off water supply to conditioner.
  - If the conditioner installation has a “three valve” bypass system, first open the valve in the bypass line, then close the valves at the conditioner inlet and outlet.
  - If the conditioner has an integral bypass valve, put it in the bypass position.
  - If there is only a shut off valve near the conditioner inlet, close it.
2. Remove valve cover and relieve water pressure in the conditioner by stepping the control into the backwash position momentarily. Return the control to the service position.
3. Unplug electrical cord from outlet.

### B. To Replace Powerhead

1. Remove the control valve cover and disconnect the power supply.
2. Remove screw and washer at drive yoke. Remove powerhead mounting screws. The entire powerhead assembly will now lift off easily.
3. Put new powerhead on top of the valve. Be sure the drive pin on main gear engages slot in drive yoke (wide side of drive yoke upright must face to the left away from the motor).
4. Replace powerhead mounting screws. Replace screw and washer at drive yoke.
5. Reconnect power supply.
6. Reinstall cover.

### C. To Replace Piston Assembly

1. Follow steps **A1 - A3**
2. Remove screw and washer at piston drive yoke. Remove powerhead mounting screws. The entire powerhead assembly will now lift off easily.
3. Remove piston retaining plate screws.
4. Pull upward on end of piston yoke until assembly is out of valve.
5. Inspect the inside of the valve to make sure that all spacers and seals are in place, and that there is no foreign matter that would interfere with the valve operation.
6. Take new piston assembly and push piston into valve by means of the end plug. Twist drive yoke carefully in a clockwise direction to properly align it with drive gear. Reinstall piston retaining plate screws.
7. Place powerhead on top of valve. Be sure drive pin on main gear engages slot in drive yoke (wide side of drive yoke upright must face to the left away from the motor).
8. Replace powerhead mounting screws. Replace screw and washer at drive yoke.

### D. To Replace Seals and Spacers

1. Follow steps **A1 - A3**.
2. Remove the control valve cover.
3. Remove screw and washer at drive yoke. Remove powerhead mounting screws. The entire powerhead assembly will now lift off easily. Remove piston retaining plate screws.
4. Pull upward on end of piston rod yoke until assembly is out of valve. Remove seals and spacers. (Note: Special end spacer must be reused)
5. Lubricate new seals with silicone lubricant included in the seal and spacer kit. Make sure the special end spacer is properly seated in the valve body. Install new seals and spacers individually, pressing around the outer edge of each seal to make sure it is seated.  
(When all seals and spacers are seated properly, you will have a 1/4” of space between the top seal the the top of the valve body)
6. Follow Steps **C7 - C10**.

**E. To Replace Injector and Screen**

1. Follow steps **A1 - A3**.
2. Remove injector cap and screws and remove cap.
3. Disassemble and clean air injection assembly (#30) and replace injector (#19)
4. Remove injector screen and clean or install a new screen (#18).
5. Apply silicone lubricant to new gasket and install on injector cap.
6. Follow F8 - F13

**SIGNATURE 2 SERIES**  
**Troubleshooting Guide**

<b>SYMPTOM</b>	<b>PROBABLE CAUSE</b>	<b>CORRECTION</b>
<b>1. Fails to Regenerate Automatically</b>	Power supply plugged into intermittent or dead power source	Connect to constant power source
	Improper control valve programming	Reset program settings
	Defective power supply	Replace power supply
	Defective Drive motor	Replace motor
<b>2. Regeneration at Wrong Time</b>	Time of day improperly set, due to power failure	Reset time of day programming and install 9-volt battery.
	Regeneration time set improperly	Reset regeneration time programming
<b>3. Poor Water Quality</b>	Check items listed in #1 and #2	
	Bypass valve open	Close bypass valve.
	Channeling	Check for too slow or high service flow. Check for media fouling.
	Lack of aeration in water	Program valve to draw air more frequently. Increase number of minutes in air draw cycle. Clean injection assembly and screen (instructions on page 13).
<b>4. Loss of Water Pressure</b>	Scaling / fouling of inlet pipe	Clean or replace pipeline. Pretreat to prevent.
	Fouled media	Clean media. Pretreat to prevent.
	Improper backwash setting	Backwash more frequently
<b>5. Continuous Flow To Drain</b>	Foreign material in control	Call dealer. Clean valve and replace pistons and seals.
	Internal control leak	Same as above.
	Valve jammed in backwash or rapid rinse position	Same as above.
	Motor stopped or jammed	Check for jammed piston. Replace piston and seals. Replace motor if motor is unresponsive.
<b>6. Media in Service Line</b>	Plumbed in backward	Re-plumb the system properly
	Internal leak in unit	Call dealer.
<b>7. Media Flows to Drain</b>	Media did not soak long enough	Re-soak the media for a longer length.
	Incorrect or missing drain flow control	Check for proper flow control (reference no. 5 on page 9). Call dealer, if problems persist.

## **Control Valve Error Code Diagnosis**

Under normal operating conditions, when your control valve is in the “in service” position, the display should alternate between the current time of day and the number of days remaining (for filters and time clock softeners) or gallons remaining (for metered softeners) until the next regeneration. This is the “home display.” If the valve is currently going through a regeneration cycle, the display will show the cycle step on the left side of the display and the number of minutes remaining in that step on the right side of the display. If any other information is being displayed, then the valve is informing you of an issue. There are five error codes which could indicate an issue with the control valve. When an error is being displayed, the valve will be in a stopped position, and the buttons will not respond to being pressed. Even if the cause of the error code is corrected, the error code will not clear until the power supply has been disconnected and reconnected (this will be referred to as “cycling” the power). All error codes are displayed as the letters “Err” followed by a flashing number 2-6:

### **Error 2 - Valve is searching for homing slot.**

Allow valve to continue running. If the homing slot is found, the valve will return to the home display, otherwise, another error code will appear.

### **Error 3 - No encoder slots are being seen.**

This occurs when the motor is running, but the encoder is not seeing any of the slots in the encoder wheel. This can happen if the encoder has been disconnected, but most commonly occurs when debris in the valve body has stopped the piston, causing the encoder wheel to be unable to turn.

1. Check encoder connection. If the encoder is plugged in and snapped into place, skip to step #2 below. If encoder is disconnected, reconnect it and cycle power to clear the error.
2. Disconnect powerhead from valve body, cycle power to clear the error code. Manually cycle the powerhead through the regeneration cycle steps to verify that the motor can cycle properly while the powerhead is disconnected from the valve body. If the error 3 does not reappear, skip to step #3 below. If the error 3 does reappear, order a board & motor kit to replace the circuit board & motor.
3. Remove piston and seals from the valve body and inspect valve body for debris. Replace the seal & spacer kit. Inspect piston and replace piston if Teflon coating is worn

### **Error 4 - Unable to find homing slot.**

1. Check encoder wheel for debris.
2. Cycle power. Valve should either find home or go to a different error code. If error 4 returns, replace powerhead assembly.

### **Error 5 - Motor overload.**

This occurs when the motor current is too high. This could be caused by an issue with the motor itself, but is typically caused by friction in the valve body

1. Disconnect powerhead from valve body and cycle power to clear the error code.
2. If the error 5 returns, replace the motor. Otherwise, manually cycle the powerhead through the regeneration cycle steps to verify that the motor can cycle properly while the powerhead is disconnected from the valve body. Either way, proceed to the next step.
3. Remove piston and seals from the valve body and inspect valve body for debris. Replace the seal & spacer kit. Inspect piston and replace piston if Teflon coating is worn.

### **Error 6 - No motor current.**

This typically occurs if the motor cable has come unplugged from the circuit board. Check that the motor cable is plugged into the circuit board and attached to the motor. If this is not the issue, the motor or circuit board may need to be replaced.

### **No Display**

If your display is blank, there is no power going to the circuit board due to one of the following factors:

- The electrical outlet is not powered or is switched off
- The power cable has come unplugged from the circuit board
- The power supply has come unplugged from your electrical outlet
- The power supply has come unplugged from the control valve
- The power supply is not working

# SIGNATURE 2 SERIES Warranty

## WATER TREATMENT EQUIPMENT

This warranty cannot be transferred - it is extended only to the original purchaser or first user of the product. By accepting and keeping this product, you agree to all of the warranty terms and limitations of liability described below.

**Important Warning:** Read carefully the CSI Water Treatment Systems Equipment Installation, Operating and Maintenance Instructions Manual to avoid serious personal injury and property HAZARDS and to ensure safe and proper care of this product.

Model Numbers Covered:  
Water Softeners, Media Filters and Upflow Filters

\*FOR AS LONG AS YOU OWN AND LIVE IN YOUR SINGLE FAMILY HOME, this warranty covers your water treatment equipment, if you are the first user of this CSI Water Treatment Systems equipment and purchased it for single family home use - subject to all of the conditions, limitations and exclusions listed below. Purchasers who buy the CSI Water Treatment Systems equipment for other purposes, and other component parts are subject to more limited warranties and you should read all of the terms included in this form to make sure you understand your warranty.

What is covered by this warranty?

CSI Water Treatment Systems warrants that at the time of manufacture, the water treatment equipment shall be free from defects in material and workmanship as follows :

Product	Warranty
Residential Mineral Tank	10 Years
Proprietary Control Valves	7 Years
Other Softener / Filter Control Valves	5 Years
Brine Tank	5 Years
Residential Reverse Osmosis System	5 Years
Other Accessories and Parts	1 Year
Brine Tank Components	1 Year
REVERE Wireless Low Salt Alarm	90 Days

\* This warranty does not include media and/or cartridge filter elements.

### Additional Terms & Conditions

What CSI Water Treatment Systems will do if you have a covered warranty claim CSI will at its option either make repairs to correct any defect in material or workmanship or supply and ship either new or used replacement parts or products. CSI will not accept any claims for labor or other costs.

### Additional Exclusions and Limitations

This warranty is non-transferable and does not cover any failure or problem unless it was caused solely by a defect in material or workmanship. In addition, this warranty shall not apply :

- If the water treatment equipment is not correctly installed, operated, repaired and maintained as described in the Installation, Operating & Maintenance Instructions Manual provided with the product.
- Defects caused as a direct result of the incoming water quality

- If the tank is not the size indicated for the supply line size of the installation, as described in the manual.
- To any failure or malfunction resulting from abuse (including freezing), improper or negligent; handling, shipping (by anyone)
- If the unit has not always been operated within the factory calibrated temperature limits, and at a water pressure not exceeding 125 psi other than CSI), storage, use, operation, accident; or alteration, lightning, flooding or other environmental conditions;
- To any failure or malfunction resulting from failure to keep the unit full of potable water, free to circulate at all times; and with the tank free of damaging water sediment or scale deposits;
- This warranty does not cover labor costs, shipping charges, service charges, delivery expenses, property damage, administrative fees or any costs incurred by the purchaser in removing or reinstalling the water treatment equipment.
- The warranty does not cover any claims submitted to CSI more than 30 days after expiration of the applicable warranty, and does not apply unless prompt notice of any claim is given to an authorized CSI Dealer or to CSI or a designated contractor is provided access to the installation and to the water treatment equipment.

THESE WARRANTIES ARE GIVEN IN LIEU OF ALL OTHER EXPRESS WARRANTIES. NO CSI REPRESENTATIVE OR ANY OTHER PARTY IS AUTHORIZED TO MAKE ANY WARRANTY OTHER THAN THOSE EXPRESSLY CONTAINED IN THIS WARRANTY AGREEMENT.

### Additional Warranty Limitations

ANY IMPLIED WARRANTIES THE PURCHASER MAY HAVE, INCLUDING THE IMPLIED WARRANTIES OF MERCHANTABILITY AND FITNESS FOR A PARTICULAR PURPOSE, SHALL NOT EXTEND BEYOND THE APPLICABLE TIME PERIODS SPECIFIED ABOVE. Some states do not allow limitations on how long an implied warranty lasts, so the above limitations may not apply to you.

### Limitations of Remedies

The remedies contained in this warranty are the purchaser's exclusive remedies. In no circumstances will CSI or the seller of the product be liable for more than, and purchaser-user's remedies shall not exceed, the price paid for the product. In no case shall CSI or seller be liable for any special, incidental, contingent or consequential damages. Special, incidental, contingent and consequential damages for which CSI is not liable include, but are not limited to, inconvenience, loss or damage to property, consequential mold damage, loss of profits, loss of savings or revenue, loss of use of the products or any associated equipment, facilities, buildings or services, downtime, and the claims of third parties including customers. Some states do not allow the exclusion or the limitation of incidental or consequential damages, so the above limitations or exclusion may not apply to you.

### What to do if you have a problem covered by this warranty

Any warranty coverage must be authorized by CSI. Contact the person from whom you purchased the product, who must receive authorization from a CSI Dealer .

If your product is new and not used and you wish to return it, contact your CSI Dealer.



**SIGNATURE 2 SERIES**

**CSI WATER TREATMENT SYSTEMS**

710 Orange St, Ashland, OH 44805 | PH 419-281-6829 | FAX 419-281-2375  
[www.csiwater.com](http://www.csiwater.com)