



**SIGNATURE 3**  
**Arsenic / Heavy Metals**

**Filter Manual**  
Installation / Operation Manual

Filter Specifications.....	Page 3
Project Data Form.....	Page 4
Media Disposal Considerations.....	Page 5
Installation Requirements.....	Page 6
Programming the Control Valve.....	Page 9
Utilizing Bluetooth.....	Page 11
Master Programming.....	Page 14
Control Valve Powerhead Assy. Sig 3.....	Page 15
Valve Body Assembly Sig. 3.....	Page 16
Bypass Assembly Sig. 3.....	Page 17
Service Instructions.....	Page 20
Troubleshooting.....	Page 21
Error Codes.....	Page 22
Warranty Information.....	Page 23

## Register Your Product

Online at  
[www.csiwater.com](http://www.csiwater.com)



FCC Compliance Statement:

[http://www.chandlersystemsinc.com/files/FCC\\_Compliance\\_Statement.pdf](http://www.chandlersystemsinc.com/files/FCC_Compliance_Statement.pdf)

Industry Canada Compliance Statement:

[http://www.chandlersystemsinc.com/files/Industry\\_Canada\\_Compliance\\_Statement.pdf](http://www.chandlersystemsinc.com/files/Industry_Canada_Compliance_Statement.pdf)

One or more features of this product are covered by U.S. patents, visit <http://csih2o.com/patents.php> for more information.

General Specifications	WFA10-S3*	WFA20-S3*	WFA30-S3*
Arsenic/Heavy Metals Adsorption Media (cu ft)	1.0	2.0	3.0
Filter Sand Underbedding (lbs.)	10	20	30
Maximum Iron (ppm)	<0.30	<0.30	<0.30
Maximum Manganese (ppm)	< .04	< .04	< .04
Maximum Service Flow Rate	5.0	8.0	11.0
Backwash Flow Rate (gpm)	2.0	4.0	5.0
Gallons Used / Backwash	30	60	75
Mineral Tank Size	9 x 48	12 x 52	13 x 65
Space Required (D X W X H)	9 x 9 x 56	12 x 12 x 60	13 x 13 x 74
Approximate Shipping Weight (lbs)	80	140	185

**NOTE:** For redundancy, a lead / lag style system (two filters plumbed in series) is highly recommended. Use of a flow control in the Service line is highly recommended. Consult the factory or your field sales person with questions.

**NOTE:** If a Whole House Arsenic / Heavy Metals Filter is recommended and installed, arsenic and / or heavy metals analysis of the treated water **MUST** be performed every six (6) months. For a lead / lag style system (two filters plumbed in series) the treated water sample should be taken between the two filters. CSI must be provided with a copy of the analysis results with system serial number and project name / address. Failure to comply with this requirement will exonerate CSI of all liability and void the system warranty. For a list of recommended water laboratories in your area, please contact your state government of residence.

**WARNING:** When a treated water analysis has detected a breakthrough of arsenic and / or heavy metals, the arsenic / heavy metals media will need to be replaced immediately. Contact your installing contractor for service. For media disposal considerations, please consult "Disposal of Titanium Oxide Media" on page 5 of these instructions.

### WARNING:

#### Lubricants

Do NOT use Vaseline, oils, hydrocarbon lubricants or spray silicone anywhere! Petroleum base lubricants will cause swelling of o-rings and seals. The use of other lubricants may attack plastic Noryl®. It is recommended that Dow Corning® silicone grease be used as a lubricant for all control valves. Dow Corning® 7 Release Compound is used in the manufacture of Chandler Systems control valves. (Part # LT-150)

#### Sealants

Pipe dope and liquid thread sealers may contain a carrier that attacks some plastic materials. It is recommended that Teflon® tape be used to seal plastic Noryl® threaded fittings.

# Project Data Form

The following information is required to size and estimate capacity of the Arsenic/Heavy Metals Filter;

Water usage information			
Number of people living in the home	_____	X 75 = _____	Estimated Total Gallons per day
Number of bathrooms	_____		
Number of bedrooms	_____		
Pumping rate of well pump	_____	GPM	
Water Analysis Summary			
	RAW WATER	TREATED WATER	COMMENTS
pH***			
Total Arsenic***			
<i>Arsenic V***</i>			
<i>Arsenic III***</i>			
Silica***			
Chromium (Total)**			
Phosphate***			
Selenium ‡**			
Uranium**			
Vanadium**			
Antimony			
Boron			
Calcium			
Copper			
<b>Iron*** (&lt; 0.3 ppm upper limit)</b>			
Lead			
<b>Manganese*** (&lt; 0.05 ppm upper limit)</b>			
Mercury			
Sulfate			
Sulfides			
Zinc			
Average Water Temperature			
Alkalinity			
Dissolved Solids***			
Hardness (As CaCo3)***			
Turbidity			

‡If Selenium is present at 25 ppb or higher, speciation will be required for selenite.

\*\*\*Denotes Required Data for Capacity Estimate

\*\*Denotes Requested Data for Improved Capacity Accuracy

**WARNING: ITEMS IN BOLD MUST BE PRE-TREATED PRIOR TO THE ARSENIC / HEAVY METAL FILTER**

### Disposal of Titanium Oxide Media

CSI Arsenic / Heavy Metals Filter Media is a titanium oxide based media that removes arsenic by adsorption to the media matrix. After many bed volumes (BV) of treated water the exhausted media is removed and replaced.

Following exhaustion, the question regarding the proper disposal of spent filter media is often asked. Many applications have determined the spent media safe for landfill disposal as a nonhazardous material. Arsenic (or "heavy metal") laden media has been evaluated using both the EPA TCLP and California WET methods and has been found to be nonhazardous and safe for landfill disposal.

Because of the concern regarding disposal of spent arsenic removal media, a study was conducted by The Center for Environmental Systems at Stevens Institute of Technology in Hoboken, New Jersey in conjunction with the New Jersey Department of Environmental Protection. This study, by Jing, Liu, Patel, and Meng and published in Environmental Science and Technology, evaluated arsenic leaching from commercially available adsorptive media. Their study found that arsenic from exhausted TiO<sub>2</sub> based media did not exceed the TCLP concentrations that would characterize the spent media as a hazardous material. They also found that titanium oxide media out performed iron based GFH under the more stringent requirements of the California WET method. An additional study by Meng et. al. showed that under reducing conditions typically found in landfills, titanium based media released significantly less arsenic than iron based media.

Typically upon exhaustion a composite sample of the media is collected and evaluated for criteria required by the regulating authority. Since each application differs, titanium oxide media should be evaluated following all federal, state, and local regulations regarding necessary approvals for landfill disposal. However, various studies have found our media to be safe for municipal landfill disposal without any special handling considerations.

Installation Requirements

- A level floor position ahead of piping into water heater.
- Unit must be installed at least 10' ahead of the inlet to a water heater to prevent damage due to back-up of hot water.
- DO NOT install the unit in an area of direct sunlight or where freezing temperatures may occur! (See Installation Diagrams for proper placement and plumbing connections.)

**ARSENIC SETUP**  
(Incoming Water from Left-Side)

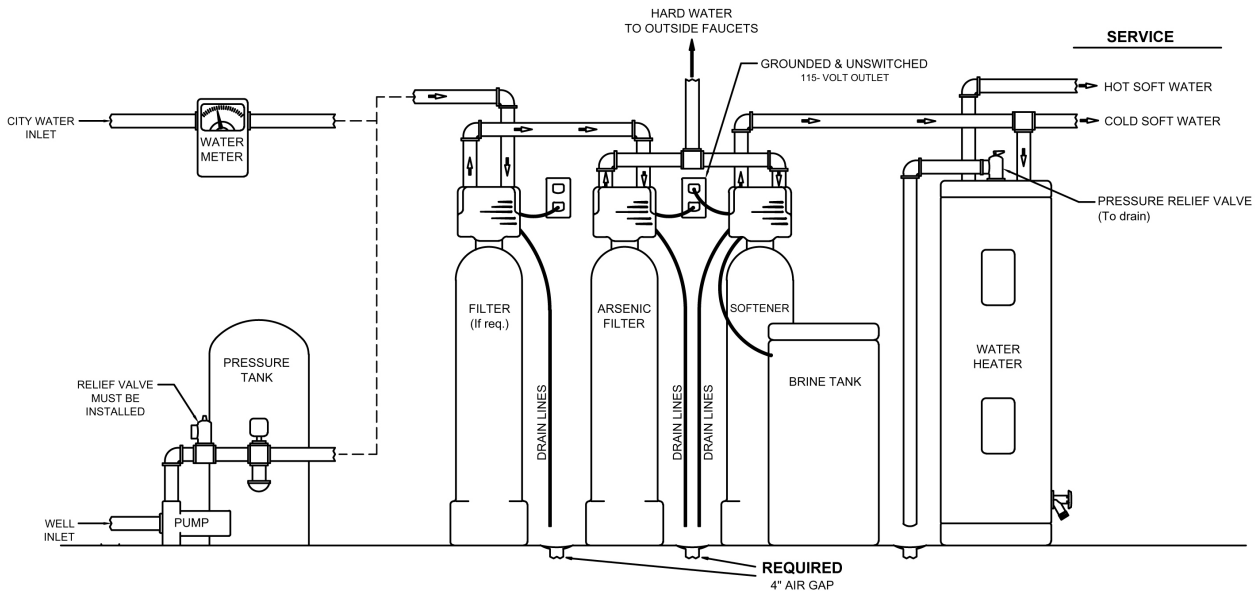

(Incoming Water from Right-Side)

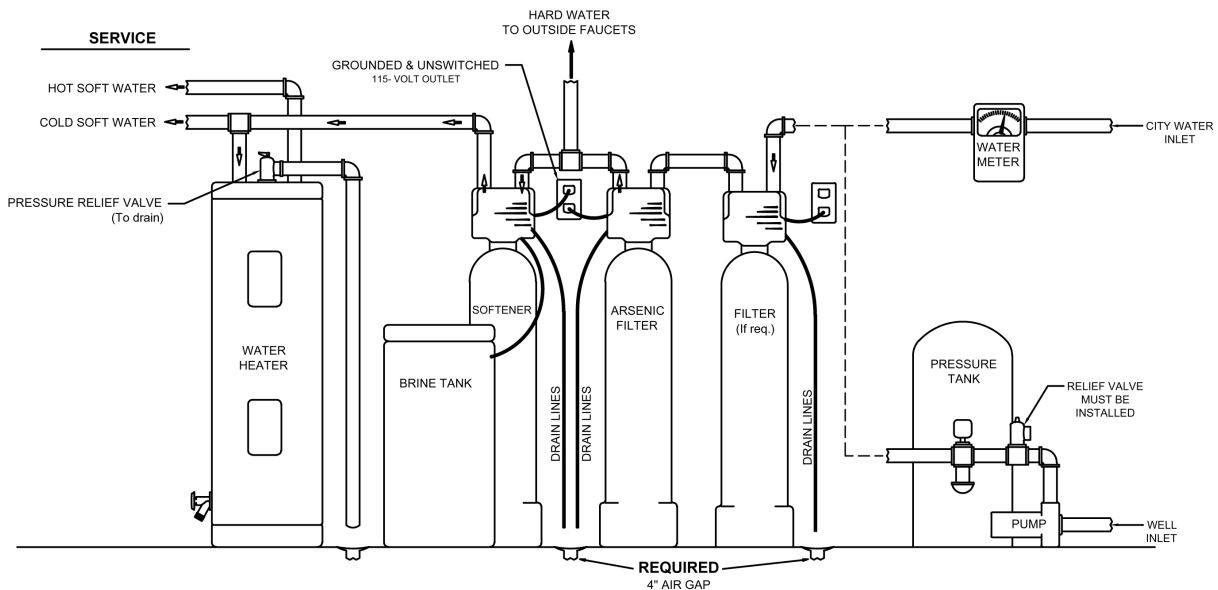

**Note:**

- If household plumbing is galvanized and you intend to make the installation with copper (or vice versa), obtain di-electric unions to prevent dissimilar metal corrosion.
- All plumbing lines not requiring “soft” water should be connected “upstream” of the softener, if installed. (See Typical Installation Diagrams.)

**Caution:**

- If sweat soldering copper pipe (remember to always use lead free solder and flux), cover yoke and bypass valve with wet rags to prevent heat damage to connections and control valve. If using PVC or plastic pipe, primers and solvent cements specifically recommended for use with potable water are required.

## Installation Procedure

### - Water Supply Connection and Bypass Valve -

To allow for filter servicing, swimming pool filling or lawn sprinkling, a manual Bypass Valve has been installed at the factory. The Bypass allows raw water to be manually routed around the filter.

1. Position filter at desired location for installation. If an iron / manganese/ sulfur filter and water softener is to be installed, the iron / sulfur filter should be positioned first then the arsenic filter and then the softener. (See Installation Diagrams.)
2. The filter material is shipped separately from the mineral tank. The tank must be loaded with material after tank has been placed at the desired location.
  - A. Remove the control valve by unscrewing from the tank.
  - B. Use cap provided to place over top of distributor tube to prevent material from entering tube while filling.
  - C. Place media funnel (part # U-1006) in hole on top of tank.
  - D. Pour several gallons of water in the tank. (Fill tank about 1/3 full.)
  - E. Pour in the required filter media. No gravel is required. The required quantity of media is listed in the filter specifications.
  - F. After filling the tank with media, use a garden hose or several buckets to fill the tank with water. This will permit the media to become soaked while preparing the installation and will prevent the control valve from being plugged with floating media on initial backwash.
  - G. Remove funnel and clean filter media from tank threads.
  - H. Remove cap from distributor tube.
  - I. Replace control valve on mineral tank. Do not use Teflon tape or paste on valve threads, as the valve to tank o-ring seals this joint.

**Caution:** Be extremely careful to position distributor tube into control valve distributor tube pilot hole.

3. Turn OFF main water supply and OPEN nearest faucet to relieve pressure.
4. Cut main line and install appropriate elbows and extensions. Inlet and outlet connections on the control valve are 1" NPT.

**Caution:** Raised arrows located on the sides of control valve body and bypass valve indicate proper direction of water flow. Install inlet and outlet piping in direction of arrows. It is recommended that a vacuum breaker be installed on the inlet plumbing.

## - Drain Line Connection -

1. The drain line flow control assembly is pre-assembled for your convenience. Should you choose to hard plumb the drain line, please remove the barb fitting. The flow control housing can be removed by removing the clip and pulling straight out on housing.

**Note:** When re-installing the drain line flow control housing, be sure you hear and feel the O-Ring pop into place before inserting the clip.

2. Install 1/2" I.D. drain line tubing (not included) from hose elbow to an open drain. A 4" gap between end of the drain line and the open drain is required to prevent waste water backflow. Keep the drain line as short as possible. An overhead drain line can be used if necessary, but should discharge below the control valve. A syphon trap (taped loop) at the outlet of the drain line is advisable to keep the drain line full and assure correct flow during backwash. Elbows or other fittings must be kept at a bare minimum.

**Note:** Where the drain line is elevated above the control valve or exceeds 20 feet in length, 3/4" I.D. drain line tubing should be used.

## - Electrical Connection -

1. Connect the power supply to the control valve and plug into a 115 volt / 60 Hz receptacle.

**Note:** Do not plug into an outlet controlled by a wall switch or pull chain that could inadvertently be turned off.

## Electronic Connections

**P - Power Supply**

**B - Powered in Backwash Step Only (Cycle #1)**

**S - Powered for Entire Backwash Cycle**

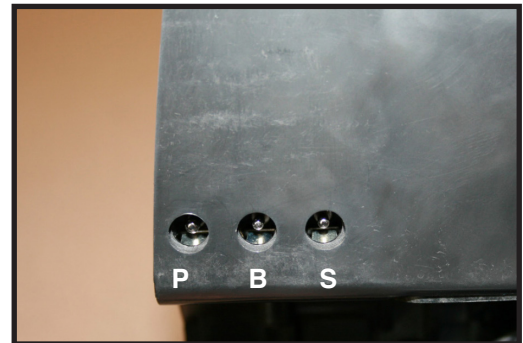

## - Pressurizing The System -

2. Slowly rotate handle of the bypass valve to the SERVICE position.
3. Open the nearest faucet to evacuate air from plumbing lines.
4. Check for leaks! If water is observed leaking from bypass, o-rings on valve body may not be seated properly. Exercise bypass valve.
5. After air is evacuated from plumbing lines, turn off faucet.

Bypass Positions



## - Initial Control Valve Operation -

1. Advance control valve to BACKWASH (cycle 1) position and allow water to run to drain until water runs clear.

**Warning:** Close handle on bypass prior to selecting the backwash position. After backwash position has been established, slightly open valve on bypass to evacuate air from the media tank. Fully open bypass valve when all air is depleted. This procedure will prevent media from being uplifted into control valve.

2. Advance control valve to RAPID RINSE (cycle 3) position and allow water to run to drain for 3 to 4 minutes.
3. Advance control valve to SERVICE (cycle 0) position.



- Final Checkout -

1. Be certain that the bypass valve is in Service position and main valve is completely on.
2. Check electrical supply to be certain the cord is connected to an uninterrupted 115 volt outlet.
3. Be certain to REGISTER YOUR PRODUCT at [www.csiwater.com](http://www.csiwater.com)
4. Leave this manual with the homeowner.

- Programming The Control Valve -

1. Set time of day.
2. Set a.m. or p.m.
3. Set number of days between backwash. (This should be set for every 14 days.)

1. Set backwash time if other than 12:00 a.m. is desired. **WARNING:** If water is used at any time during the backwash cycle, **untreated** water will bypass to service unless a lead / lag style (two filters plumbed in series) installation is utilized.

Main Menu

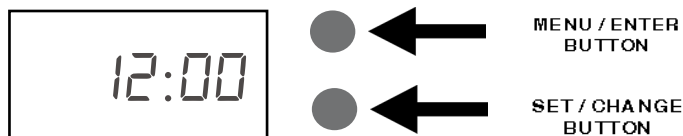

1. To enter Main Menu, press the **Menu/Enter** button.  
(Time of Day will flash)
2. To set the **Time of Day**, press the **Set/Change** button.  
(First digit will flash) Example [ 12:00 ]  
To change digit value, press the **Set/Change** button.
  - To accept the digit value, press the **Menu/Enter** button.
  - Next digit will flash to begin setting.
  - Once the last digit display is accepted, all digits will flash.
3. To set **A.M.** or **P.M.**, press the **Menu/Enter** button.
  - To change digit value, press the **Set/Change** button. Example [ A ]
  - To accept the digit value, press the **Menu/Enter** button.
  - Once A.M. or P.M. is accepted, the next menu item will flash.
4. a. To set the **Number of Days between Backwash Cycles (A)**, press the **Set/Change** button.  
Repeat instructions from step (2). Example [ A - 14 ]

**Notes:** 1) Maximum value is 29.  
2) If value set to 0, Automatic Backwash will never occur.  
3) Default setting is 14 days for arsenic / heavy metal filters.
5. To Exit Main Menu, press the **Menu/Enter** button.  
**Note:** If no buttons are pressed for 60 seconds, the Main Menu will be exited automatically.

## Normal Operation

### 1. Home Display

- a. Alternates between the display of Time of Day and Number of Days until the Next Backwash.
  - Days Remaining until the Next Backwash will count down from the entered value until it reaches 1 day remaining.
  - A Backwash Cycle will then be initiated at the next designated regeneration time.

### 2. Battery Back-Up (Uses a standard 9-volt alkaline battery, not included.)

#### Features of Battery Back-Up:

- During power failures, the battery will maintain the time of day as long as the battery has power. The display is turned off to conserve battery power during this time. To confirm that the battery is working, press either button and the display will turn on for five (5) seconds.
- If power failure occurs while system is backwashing, the valve will motor to a shut off position to prevent constant flow to drain. Depending upon system pressure and other factors, it is possible to observe a reduced flow to drain during this step. After Power is restored, the valve will return and finish the cycle where it left off prior to the power interruption.
- When used without battery back-up, during a power failure, the unit stops at its current point in the backwashing position and then restarts at that point when the power is restored. The time will be offset by the increment of time the unit was without power, so it is necessary to reset the time of day on the unit. No other system will be affected.

## Starting Extra Regeneration Cycle

### 1. To Start Delayed Extra Cycle

Example ( 1 )

- If Days Remaining Until Next Backwash does not read '1', press and hold the **Set/Change** button for 3 seconds until the display reads '1'.
- Backwash cycle will initiate at the next designated backwash time.

### 2. To start Immediate Extra Cycle First complete above step.

- With Days Remaining Until Next Backwash at '1'.
- Press and hold the **Set/Change** button.
- After 3 seconds, the backwash cycle will begin.

### 3. To Fast Cycle thru Backwash First complete above 2 steps.

**Note:** Press and hold the **Set/Change** button for 3 seconds to advance to the next cycle step. Fast Cycle is not necessary unless desired to manually step through each cycle step. (Repeat until valve returns to the home display)

Arsenic Filters	Default (Min)	
Step 1	Backwash	10
Step 2	Rest	5
Step 3	Rapid Rinse	5
Step 4	Not Used	0



For simplified set up and control, please install the Legacy View on a compatible Bluetooth 4.0+ enabled smart phone or tablet.

1. Download and install the Legacy View app from the Google Play Store, Apple App Store

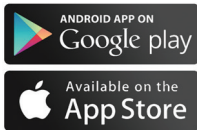

2. Open the Legacy View app

- Choose a valve device at any time from the list of available devices to connect to by clicking on it.
- If the valve you want to connect to doesn't show up, or there is a problem connecting to a device you can press the "Scan for Devices" button or the Legacy View logo at any time to refresh the list and start the process over.
- If the valve device is a BTLE valve and it has a password other than the default password, the first time you connect to it the app will ask you to enter the password. After entering it the first time you should not need to enter it again unless it changes.

3. BTLE Valve devices can be updated by the App. When the app is updated from the Google Play Store or the Apple App Store, it may contain an updated firmware program for the valve devices. These updates could contain new features or operational improvements. It is up to the user to allow these updates to be sent to the valve device. Uploading a new program takes approximately 1 minute.

## Dashboard

NOTE: Consult your dealer before making any changes

From the **Dashboard**, all items in can be changed, while blue fields are informational only.



If you are unsure about the function of the field click the for more information.

## Set Up Utilizing Bluetooth App

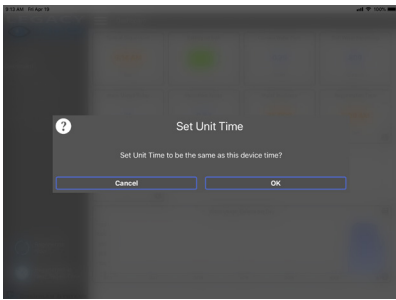

Change Time of Day (Press “SET” to set time automatically based on device).

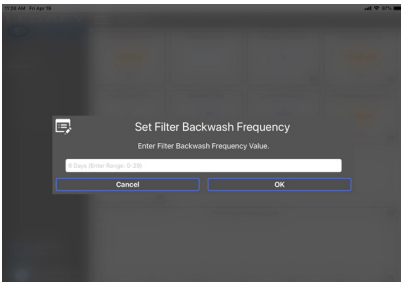

For Filters:  
Set Backwash Frequency  
This sets the amount of day between backwash cycles

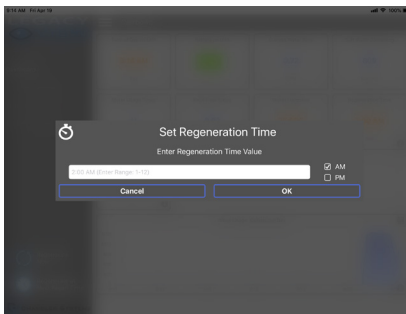

Set Regeneration Time  
Example: For 2a.m., just type 2, choose a.m., and press ‘OK’  
Note: If you have a filter and a softener the valves should be set to regenerate at different times. Factory default times are 12a.m. for filters, and 2 a.m. for softeners.

## Advanced Settings

**NOTE:** Consult your dealer before making any changes. We do not recommend changing Advanced Settings unless you have a good understanding of the system operation.

From the **Advanced Settings**, all items in **ORANGE** with a “set” button can be changed.

## Status and History

From the Status and History, all items in **ORANGE** can be reset.



Pressing this icon will show a list of the data that is in the graph.

Touch any graph to enlarge and see details. Enlarged graphs are able to be zoomed in by pinching with two fingers. (Enlarged graph shown below)

Pressing the .csv logo in the corner will allow the graph data to be exported and shared.

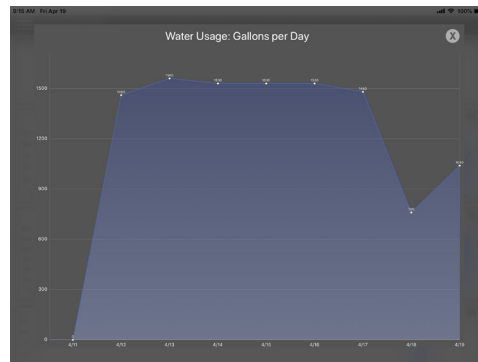

Enlarged graph showing water usage

### 1. Start a regeneration or backwash cycle

Option 1:

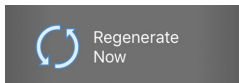

Click the “Regenerate Unit Now.”

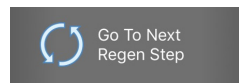

Once a regeneration has been started, if you would like to force the unit into the next cycle step click “Go to Next Regeneration Step”.

Option 2:

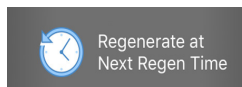

“Regenerate Unit at Next Regen Time” button  
This will take the system into a backwash cycle at the next regeneration time.

## Master Programming Mode

To enter Master Programming Mode, press and hold both buttons for 5 seconds.

Note: All Master Programming functions have been preset at the factory. Unless a change is desired, it is **NOT** necessary to enter Master Programming Mode.

### 1. Backwash Time ( r )

Example [ r 1A ]

- The time of day at which backwash may take place is designated by the letter "r".
- Default regeneration time settings is **1a**
- The first display digit indicates A.M. or P.M. To change the value, press the **Set/Change** button.
- Press **Menu/Enter** button to accept the value and move to the next digit.
- The second and third display digits indicate the hour at which the backwash will occur.
- Change the digits with the **Set/Change** button and accept with the **Menu/Enter** button.
- After the entire display flashes, press the **Menu/Enter** button to move to the next menu item.

### 2. Backwash Cycle Step Times (Steps 1, 2, 3, 4)

Example [ 3 - 10 ]

- The next 4 displays set the duration of time in minutes for each backwash cycle step.
- The step number which is currently modifiable is indicated on the far left of the display screen.
- The number of minutes allotted for the selected backwash step is displayed on the far right.
- Change the digit values using the **Set/Change** and **Menu/Enter** buttons as described above.

### 3. Bluetooth Enabled

bE - 1 (ON)

bE - 0 (OFF)

### 4. Bluetooth Password

bEPP is displayed for one second, then password is displayed.

### 5. Display Off

do-0 (OFF) Default

do-1 (ON)

6. To Exit the Master Programming Mode, press the **Menu/Enter** button until time of day returns.

**Note:** If no buttons are pressed for 60 seconds, the Master Programming Mode will be exited automatically.

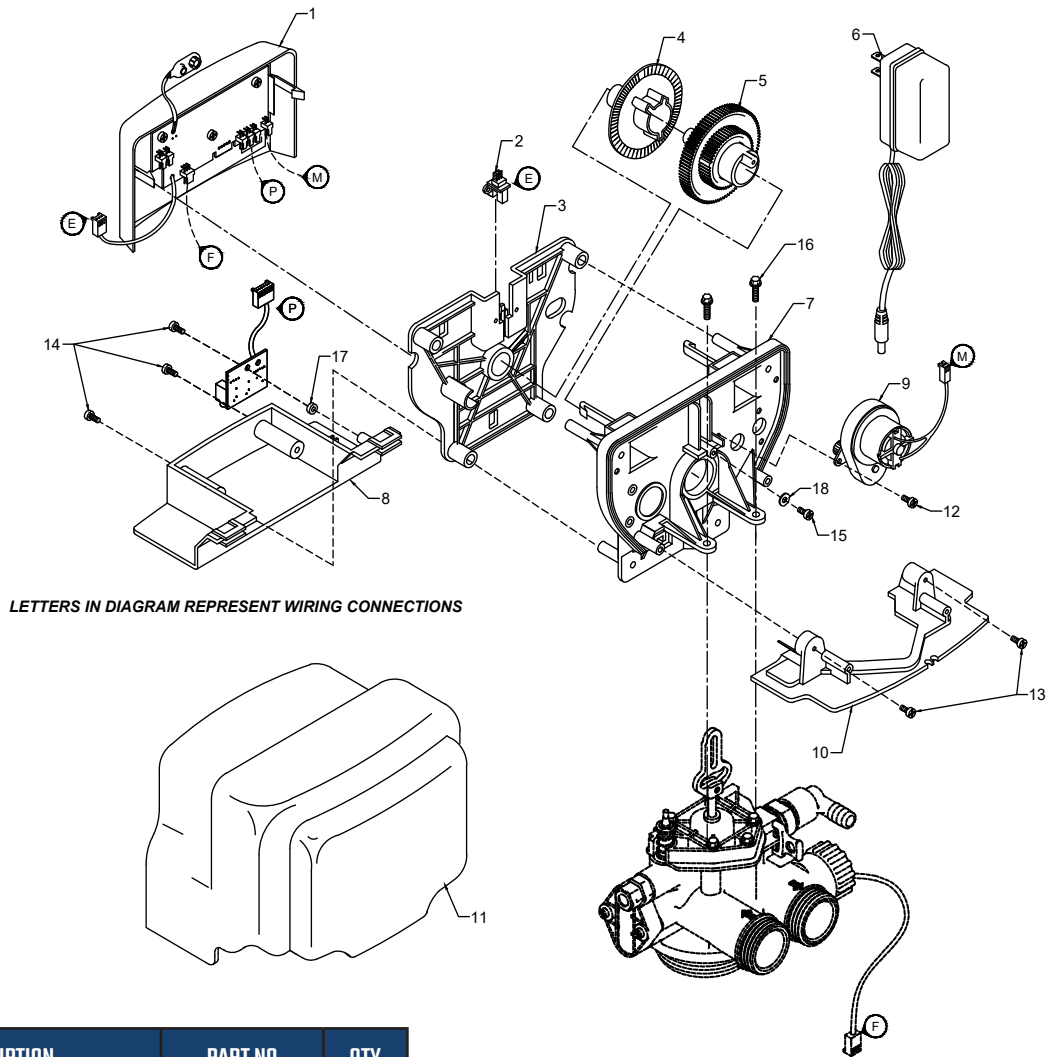

REF	DESCRIPTION	PART NO	QTY
0	Power Head Assy.	21002X100	1
1	Filter Circuit Boad Assy.	21002X101	1
2	Encoder	20001X124	1
3	Front Plate	20001X004	1
4	Encoder Wheel	20001X007	1
5	Main Gear	21001X120	1
6	Power Supply	20001X125	1
7	Back Plate	20001X005	1
8	Lower Front Base For Cover	20111X002	1
9	Motor	20016X006	1
10	Lower Back Base for Cover	20111X003	1
11	Valve Cover	20111X000	1
12	Piston Screw	20001X003	1
13	Screw	SC10	3
14	Screw	SC9	2
15	6 X 1/2 Fenderwasher SST	20001X002	1
16	Washer Circuit Board	20111X014	1
17	Screw Motor	SC2	1
21	Valve Hex Screw	20001X001	2

# Valve Body Assembly - SIGNATURE 3

REF	DESCRIPTION	PART NO.	QTY
1	Piston Assembly	20001X231	1
2	10-24 X 3/4" Screw SST	20001X001	3
3	Seal and Spacer Kit Incl (5) #3 & (4) #4	20561X253	1
4	End Spacer	20001X234	1
5	Flow Control Button 5.0 GPM	20251X272	1
	Flow Control Button 7.0 GPM	20251X273	1
6A	DLFC Assy.	20017X251	1
7	90 Degree Hose Barb Elbow	20017X266	1
8	Brine Valve Plug w/ O-Ring	20001X230	1
9	Filter Plug Assy. w/ O-Ring	20001X229	1
10	10-24 X 3/4" Screw SST	20001X001	2
11	Injector Cap	20001X223	1
12	Injector Seal	20001X224	1
13	Injector Plug & O-Ring Assy.	20001X217	1
14	Injector Screen	20001x222	1
15	Injector Plug & O-Ring Assy.	20001X217	1
16	Valve O-Ring	20015X043	1
17	Dist. O-Ring	20561X204	1
18	Meter Assembly	20017X203	

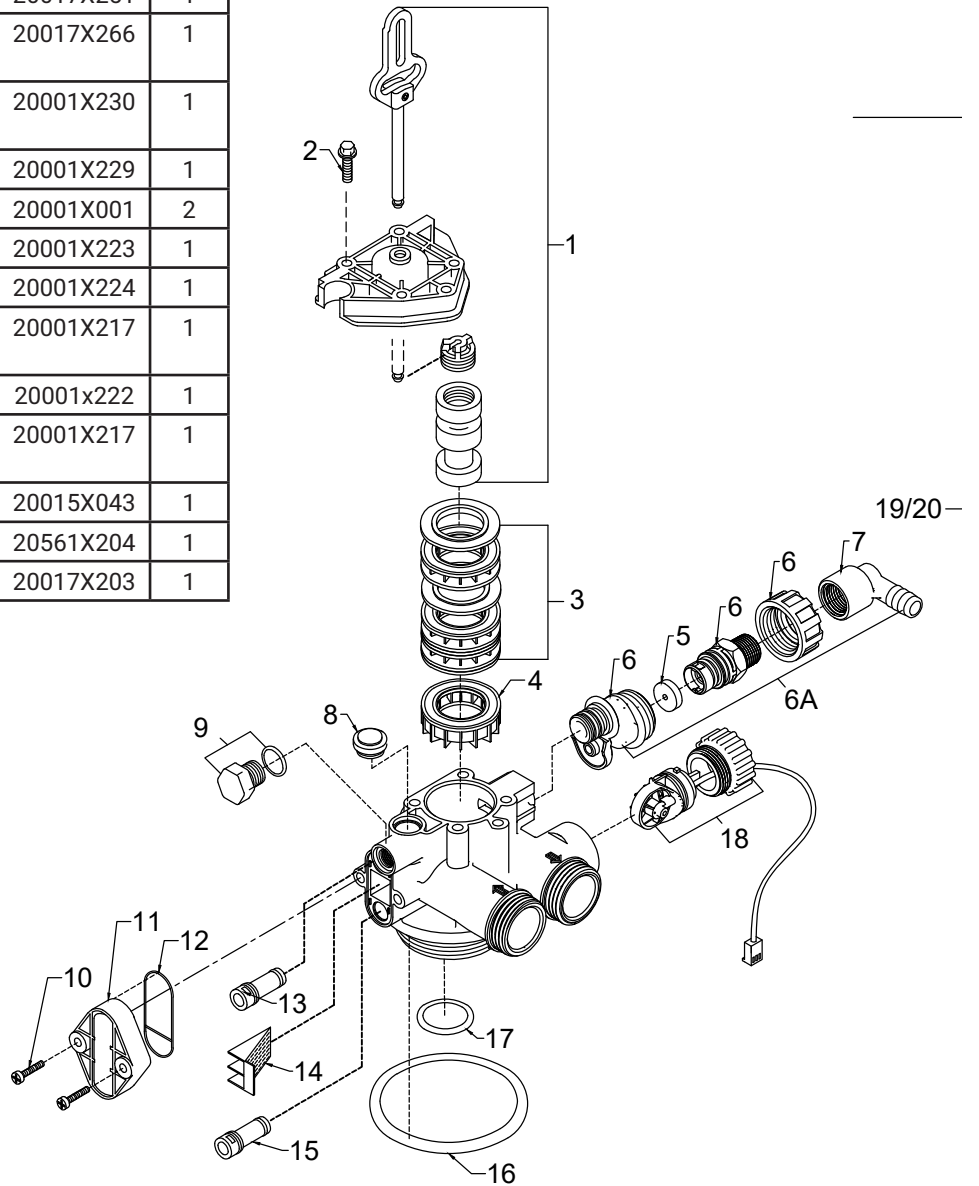



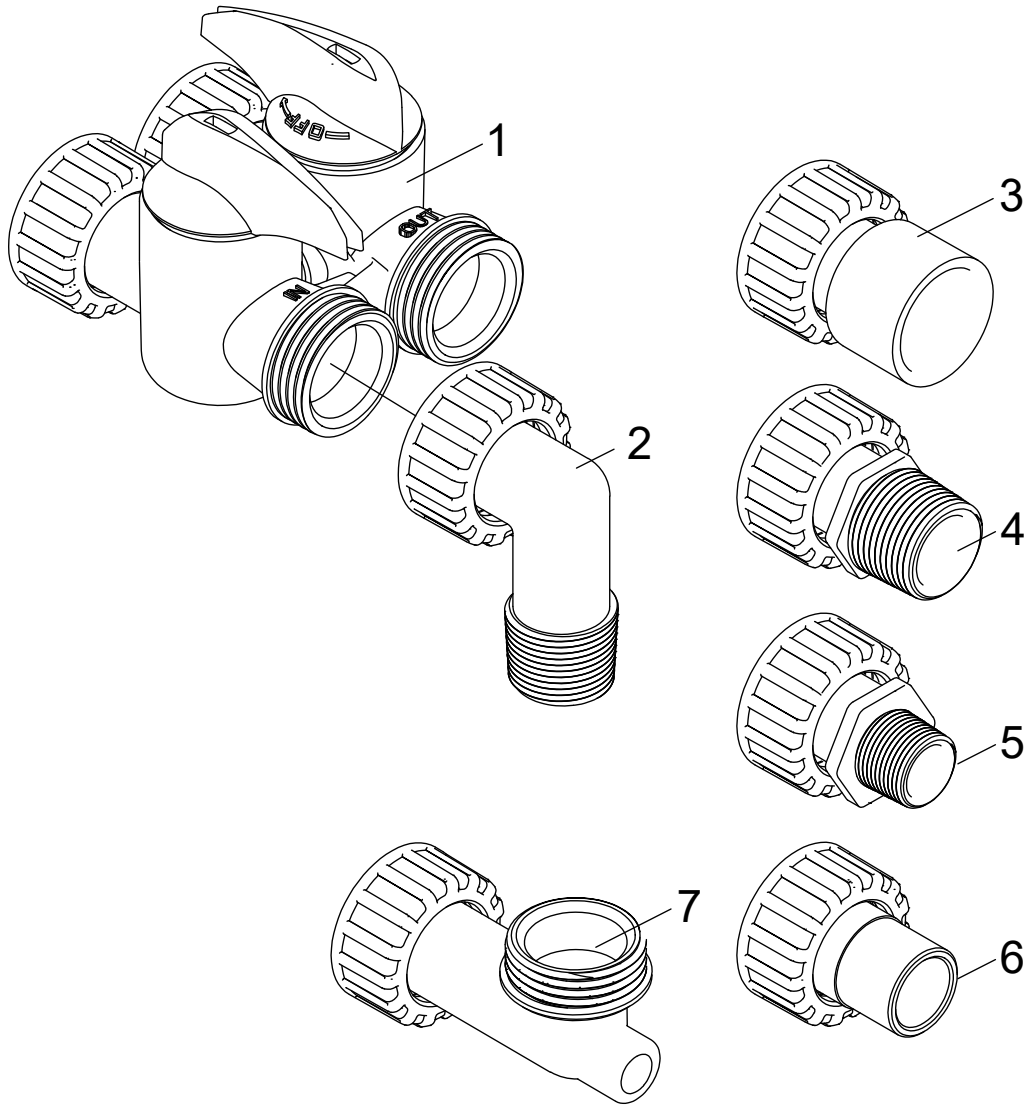

REF	DESCRIPTION	PART NO.
1	D15 Bypass (included with all units)	20017X283
2	1" NPT Elbow Set (included with all units)	20017X284
3	1" Female Straight Slip Set (optional)	20017X288
4	1" NPT Straight Set (optional)	20017X289
5	3/4" NPT Straight Set (optional)	20017X307
6	1" x 3/4" Brass Sweat Connector (optional)	20017X304
7a	Elbow, Vertical Adapter Blank (optional)	20017X295
7b	Elbow, Vertical Adapter 1/4" NPT Tapped (optional)	20017X294

**A. General Preliminary Instructions**

**PERFORM BEFORE ALL SERVICING OPERATIONS**

1. Turn off water supply to conditioner.
  - If the conditioner installation has a “three valve” bypass system, first open the valve in the bypass line, then close the valves at the conditioner inlet and outlet.
  - If the conditioner has an integral bypass valve, put it in the bypass position.
  - If there is only a shut off valve near the conditioner inlet, close it.
2. Remove cover and relieve water pressure in the conditioner by stepping the control into the backwash position momentarily. Return the control to the service position.
3. Unplug electrical cord from outlet.

**B. To Replace Powerhead**

1. Remove the control valve cover and disconnect the power supply.
2. Disconnect the meter cable from circuit board and feed back through control (if existing meter is being re-used)
3. Remove lower back base screws and detach lower back base.
4. Remove screw and washer at drive yoke. Remove powerhead mounting screws. The entire powerhead assembly will now lift off easily.
5. Put new powerhead on top of the valve. Be sure the drive pin on main gear engages slot in drive yoke (wide side of drive yoke upright must face to the left away from the motor).
6. Replace powerhead mounting screws. Replace screw and washer at drive yoke.
7. Reattach lower back base.
7. Reconnect meter signal, wire and power supply.
8. Reinstall cover.

**C. To Replace Piston Assembly**

1. Follow steps **A1 - A3**
2. Disconnect the meter signal wire from the circuit board.
3. Remove lower back base screws and detach lower back base.
4. Remove screw and washer at piston drive yoke. Remove powerhead mounting screws. The entire power head assembly will now lift off easily.
5. Remove piston retaining plate screws.
6. Pull upward on end of piston yoke until assembly is out of valve.
7. Inspect the inside of the valve to make sure that there is no foreign matter that would interfere with the valve operation.
8. Install new seals and spacers.
9. Take new piston assembly and push piston into valve by means of the end plug. Twist drive yoke carefully in a clockwise direction to properly align it with drive gear. Reinstall piston retaining plate screws.
10. Follow steps **B5 - B9**

**D. To Replace Seals and Spacers**

1. Follow steps **A1 - A3**.
2. Disconnect the meter signal wire from the circuit board.
3. Remove screw and washer at piston drive yoke. Remove powerhead mounting screws. The entire power head assembly will now lift off easily. Remove piston retaining plate screws.
4. Pull upward on end of piston rod yoke until assembly is out of valve. Remove seals and spacers. (**Note:** Special end spacer must be reused)
5. Lubricate new seals with silicone lubricant included in the seal and spacer kit. Make sure the special end spacer is properly seated in the valve body. Install new seals and spacers individually, pressing around the outer edge of each seal to make sure it is seated. (When all seals and spacers are seated properly, you will have a 1/4” of space between the top seal the the top of the valve body)
6. Follow Steps **C9 - C10**.

**E. To Replace Meter**

1. Follow steps **A1 - A3**
2. Unplug meter cable from front of circuit board.
3. Unscrew meter assembly nut from valve body.
4. Remove meter from valve body and clean or replace as necessary.
5. Reinstall meter, nut and cable.

SYMPTOM	PROBABLE CAUSE	CORRECTION
<b>1. Filter Fails to Regenerate Automatically</b>	Power supply unplugged or plugged into intermittent or dead power source	Connect to constant power source
	Improper control valve programming	Reset program settings
	Defective power supply	Replace power supply
	Defective Drive motor	Replace motor
<b>2. Regeneration at Wrong Time</b>	Time of day improperly set, due to power failure	Reset time of day programming and install 9-volt battery.
	Regeneration time set improperly	Reset regeneration time programming
	Power supply plugged into a switched or intermittent power source	Connect to constant power source
<b>3. Poor Water Quality</b>	Check items listed in #1 and #2	
	Bypass valve open	Close bypass valve.
	Channeling	Check for too slow or high service flow. Check for media fouling.
<b>4. Loss of Water Pressure</b>	Scaling / fouling of inlet pipe	Clean or replace pipeline. Pretreat to prevent.
	Fouled media	Clean media. Pretreat to prevent.
	Improper backwash setting	Backwash more frequently
<b>5. Continuous Flow to Drain</b>	Foreign material in control	Call dealer. Clean valve and replace piston and seals
	Internal control leak	Same as above.
	Valve jammed in backwash, brine or rapid rinse position	Same as above.
	Motor stopped or jammed	Check for jammed piston. Replace piston and seals. Replace motor if motor is unresponsive.

### Control Valve Error Code Diagnosis

Under normal operating conditions, when your control valve is in the “in service” position, the display should alternate between the current time of day and the number of days remaining (for filters and time clock softeners) or gallons remaining (for metered softeners) until the next regeneration. This is the “home display.” If the valve is currently going through a regeneration cycle, the display will show the cycle step on the left side of the display and the number of minutes remaining in that step on the right side of the display. If any other information is being displayed, then the valve is informing you of an issue. There are five error codes which could indicate an issue with the control valve. When an error is being displayed, the valve will be in a stopped position, and the buttons will not respond to being pressed. Even if the cause of the error code is corrected, the error code will not clear until the power supply has been disconnected and reconnected (this will be referred to as “cycling” the power). All error codes are displayed as the letters “Err” followed by a flashing number 2-6:

#### **Error 2** - Valve is searching for homing slot.

Allow valve to continue running. If the homing slot is found, the valve will return to the home display, otherwise, another error code will appear.

#### **Error 3** - No encoder slots are being seen.

This occurs when the motor is running, but the encoder is not seeing any of the slots in the encoder wheel. This can happen if the encoder has been disconnected, but most commonly occurs when debris in the valve body has stopped the piston, causing the encoder wheel to be unable to turn.

1. Check encoder connection. If the encoder is plugged in and snapped into place, skip to step #2 below. If encoder is disconnected, reconnect it and cycle power to clear the error.
2. Disconnect powerhead from valve body, cycle power to clear the error code. Manually cycle the power head through the regeneration cycle steps to verify that the motor can cycle properly while the powerhead is disconnected from the valve body. If the error 3 does not reappear, skip to step #3 below. If the error 3 does reappear, order a board & motor kit to replace the circuit board & motor.
3. Remove piston and seals from the valve body and inspect valve body for debris. Replace the seal & spacer kit. Inspect piston and replace piston if Teflon coating is worn

#### **Error 4** - Unable to find homing slot.

1. Check encoder wheel for debris.
2. Cycle power. Valve should either find home or go to a different error code. If error 4 returns, replace powerhead assembly.

#### **Error 5** - Motor overload.

This occurs when the motor current is too high. This could be caused by an issue with the motor itself, but is typically caused by friction in the valve body

1. Disconnect powerhead from valve body and cycle power to clear the error code.
2. If the error 5 returns, replace the motor. Otherwise, manually cycle the powerhead through the regeneration cycle steps to verify that the motor can cycle properly while the powerhead is disconnected from the valve body. Either way, proceed to the next step.
3. Remove piston and seals from the valve body and inspect valve body for debris. Replace the seal & spacer kit. Inspect piston and replace piston if Teflon coating is worn.

#### **Error 6** - No motor current.

This typically occurs if the motor cable has come unplugged from the circuit board. Check that the motor cable is plugged into the circuit board and attached to the motor. If this is not the issue, the motor or circuit board may need to be replaced.

#### **No Display**

If your display is blank, there is no power going to the circuit board due to one of the following factors:

- The electrical outlet is not powered or is switched off
- The power cable has come unplugged from the circuit board
- The power supply has come unplugged from your electrical outlet
- The power supply has come unplugged from the control valve
- The power supply is not working

## WATER TREATMENT EQUIPMENT

This warranty cannot be transferred - it is extended only to the original purchaser or first user of the product. By accepting and keeping this product, you agree to all of the warranty terms and limitations of liability described below.

**Important Warning:** Read carefully the CSI Water Treatment Systems Equipment Installation, Operating and Maintenance Instructions Manual to avoid serious personal injury and property HAZARDS and to ensure safe and proper care of this product.

Model Numbers Covered:

Water Softeners, Media Filters and Upflow Filters

\*FOR AS LONG AS YOU OWN AND LIVE IN YOUR SINGLE FAMILY HOME, this warranty covers your water treatment equipment, if you are the first user of this CSI Water Treatment Systems equipment and purchased it for single family home use - subject to all of the conditions, limitations and exclusions listed below. Purchasers who buy the CSI Water Treatment Systems equipment for other purposes, and other component parts are subject to more limited warranties and you should read all of the terms included in this form to make sure you understand your warranty.

What is covered by this warranty?

CSI Water Treatment Systems warrants that at the time of manufacture, the water treatment equipment shall be free from defects in material and workmanship as follows:

Component	Warranty
Residential Mineral Tank	10 Years
Proprietary Control Valves	7 Years
Other Softener / Filter Control Valves	5 Years
Brine Tank	5 Years
Residential Reverse Osmosis System	5 Years
Other Accessories and Parts	1 Year
Brine Tank Components	1 Year

\* This warranty does not include media and/or cartridge filter elements.

### Additional Terms & Conditions

What CSI Water Treatment Systems will do if you have a covered warranty claim CSI will at its option either make repairs to correct any defect in material or workmanship or supply and ship either new or used replacement parts or products. CSI will not accept any claims for labor or other costs.

### Additional Exclusions and Limitations

This warranty is non-transferable and does not cover any failure or problem unless it was caused solely by a defect in material or workmanship. In addition, this warranty shall not apply:

- If the water treatment equipment is not correctly installed, operated, repaired and maintained as described in the Installation, Operating & Maintenance Instructions Manual provided with the product.
- Defects caused as a direct result of the incoming water quality
- If the tank is not the size indicated for the supply line size of the installation, as described in the manual.
- To any failure or malfunction resulting from abuse (including

- freezing), improper or negligent; handling, shipping (by anyone
- If the unit has not always been operated within the factory calibrated temperature limits, and at a water pressure not exceeding 125 psi other than CSI), storage, use, operation, accident; or alteration, lightning, flooding or other environmental conditions;
- To any failure or malfunction resulting from failure to keep the unit full of potable water, free to circulate at all times; and with the tank free of damaging water sediment or scale deposits;
- This warranty does not cover labor costs, shipping charges, service charges, delivery expenses, property damage, administrative fees or any costs incurred by the purchaser in removing or reinstalling the water treatment equipment.
- The warranty does not cover any claims submitted to CSI more than 30 days after expiration of the applicable warranty, and does not apply unless prompt notice of any claim is given to an authorized CSI Dealer or to CSI or a designated contractor is provided access to the installation and to the water treatment equipment.

THESE WARRANTIES ARE GIVEN IN LIEU OF ALL OTHER EXPRESS WARRANTIES. NO CSI REPRESENTATIVE OR ANY OTHER PARTY IS AUTHORIZED TO MAKE ANY WARRANTY OTHER THAN THOSE EXPRESSLY CONTAINED IN THIS WARRANTY AGREEMENT.

### Additional Warranty Limitations

ANY IMPLIED WARRANTIES THE PURCHASER MAY HAVE, INCLUDING THE IMPLIED WARRANTIES OF MERCHANTABILITY AND FITNESS FOR A PARTICULAR PURPOSE, SHALL NOT EXTEND BEYOND THE APPLICABLE TIME PERIODS SPECIFIED ABOVE. Some states do not allow limitations on how long an implied warranty lasts, so the above limitations may not apply to you.

### Limitations of Remedies

The remedies contained in this warranty are the purchaser's exclusive remedies. In no circumstances will CSI or the seller of the product be liable for more than, and purchaser-user's remedies shall not exceed, the price paid for the product. In no case shall CSI or seller be liable for any special, incidental, contingent or consequential damages. Special, incidental, contingent and consequential damages for which CSI is not liable include, but are not limited to, inconvenience, loss or damage to property, consequential mold damage, loss of profits, loss of savings or revenue, loss of use of the products or any associated equipment, facilities, buildings or services, downtime, and the claims of third parties including customers. Some states do not allow the exclusion or the limitation of incidental or consequential damages, so the above limitations or exclusion may not apply to you.

### What to do if you have a problem covered by this warranty

Any warranty coverage must be authorized by CSI. Contact the person from whom you purchased the product, who must receive authorization from a CSI Dealer.

If your product is new and not used and you wish to return it, contact your CSI Dealer.





## **CSI WATER TREATMENT SYSTEMS**

710 Orange St, Ashland, OH 44805 | PH 419-281-6829 | FAX 419-281-2375  
[www.csiwater.com](http://www.csiwater.com)

1024TV