



WATER TREATMENT SYSTEMS



SIGNATURE 3

Reactr

Installation / Operation Manual

General Specifications.....	Page 3
Installation Requirements.....	Page 4
ProgrammingtheControlValve.....	Page 7
Utilizing Bluetooth.....	Page 9
Master Programming.....	Page 12
Control Valve Powerhead Assy. Sig 3.....	Page 13
Manifoold Assy. Sig 3.....	Page 14
Valve Body Assembly Sig. 3.....	Page 15
Bypass Assembly Sig. 3.....	Page 16
Service Instructions.....	Page 17
Troubleshooting.....	Page 18
Error Codes.....	Page 19
Warranty Information.....	Page 20

Register Your Product

Online at
www.csiwater.com



CSI
WATER TREATMENT SYSTEMS

FCC Compliance Statement:

[http://www.chandlersystemsinc.com/files/FCC Compliance Statement.pdf](http://www.chandlersystemsinc.com/files/FCC%20Compliance%20Statement.pdf)

Industry Canada Compliance Statement:

[http://www.chandlersystemsinc.com/files/Industry Canada Compliance Statement.pdf](http://www.chandlersystemsinc.com/files/Industry%20Canada%20Compliance%20Statement.pdf)

One or more features of this product are covered by U.S. patents, visit <http://csih2o.com/patents.php> for more information.

The Reactr™ requires no chemicals for its operation. It consists of two components: (1) Reactr™ Tank and (2) Filter Tank. The Reactr Tank serves to oxidize and percitate iron and sulfur so that they can later be removed by the filter. The water flows down through the mineral bed of the filter and out of the service lines. The collected percipitates must be regularly removed from the filter by reversing the flow of water through the filter and running to the drain. Called “Backwashing” and lasting 10 minutes, the process expands the mineral, freeing the iron, sulfur and turbidity, which is then washed out of the filter to the drain. It is important that the correct amount of water is available for the backwash cycle. Check pump capacity to be certain water is available in sufficient volume to adequately backwash the equipment at a specified rate.

General Specifications	RF15-S3	RF20-S3	RF25-S3	RF30-S3
Filter Media Type	SmartBlend™			
Filter Media Capacity (cu ft)	1.5	2.0	2.5	3.0
REACTR™ Tank Size	10 x 54	10 x 54	10 x 54	16 x 40
Mineral Tank Size	10 x 54	12 x 52	13 x 54	13 x 65
Service Flow Rate - Continuous (gpm)	5	6	8	9
Service Flow Rate - Intermittent (gpm)	7	8	10	11
Backwash Flow Rate (gpm)	5.0	6.0	7.0	7.0
Gallons Used / Backwash	100	120	140	140
Space Required (D x W x H)	10 x 10 x 62	10 x 12 x 62	10 x 13 x 62	16 x 16 x 73
Approximate Shipping Weight (lbs)	165	236	270	311

WARNING

Lubricants

Do NOT use Vaseline, oils, hydrocarbon lubricants or spray silicone anywhere! Petroleum base lubricants will cause swelling of o-rings and seals. The use of other lubricants may attack plastic Noryl®. It is recommended that Dow Corning® silicone grease be used as a lubricant for all control valves. Dow Corning® 7 Release Compound is used in the manufacture of Chandler Systems control valves. (Part # LT-150)

Sealants

Pipe dope and liquid thread sealers may contain a carrier that attacks some plastic materials. It is recommended that Teflon® tape be used to seal plastic Noryl® threaded fittings.

Installation Requirements

- A level floor position ahead of piping into water heater.
- Unit must be installed at least 10' ahead of the inlet to a water heater to prevent damage due to back-up of hot water.
- **DO NOT** install the unit in an area of direct sunlight or where freezing temperatures may occur!
(See Installation Diagrams for proper placement and plumbing connections.)

"RF" SERIES REACTR

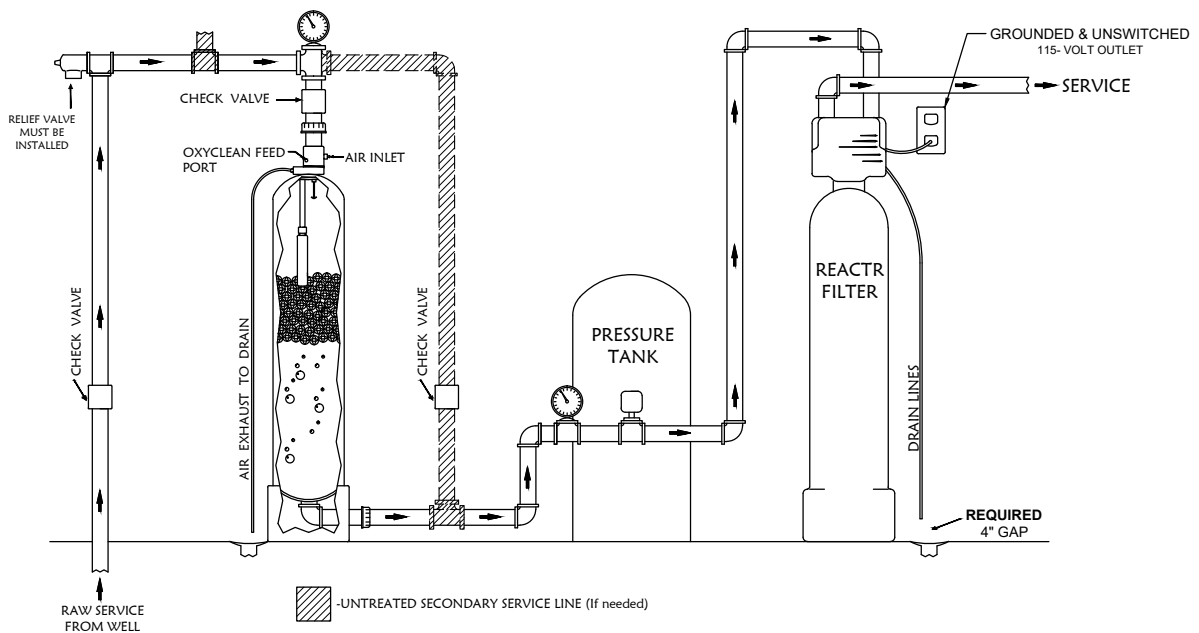

Note:

- If household plumbing is galvanized and you intend to make the installation with copper (or vice versa), obtain di-electric unions to prevent dissimilar metal corrosion.
- If sweat soldering copper pipe (remember to always use lead free solder and flux), cover yoke and bypass valve with wet rags to prevent heat damage to connections and control valve. If using PVC or plastic pipe, primers and solvent cements specifically recommended for use with potable water are required.

Installation Procedure

- Water Supply Connection and Bypass Valve -

To allow for filter servicing, swimming pool filling or lawn sprinkling, a manual Bypass Valve has been installed at the factory. The Bypass allows raw water to be manually routed around the filter.

Caution: Raised arrows located on the sides of control valve body and bypass valve indicate proper direction of water flow. Install inlet and outlet piping in direction of arrows. It is recommended that a vacuum breaker be installed on the inlet plumbing.

1. Position filter at desired location for installation. If a water softener is to be installed, the filter should be positioned first and then the softener.
2. The filter material is shipped separately from the mineral tank. The tank must be loaded with material after tank has been placed at the desired location.
 - A. Remove the control valve by unscrewing from the tank. (Do not fill through dome hole, if installed.)
 - B. Use cap provided to place over top of distributor tube to prevent material from entering tube while filling.
 - C. Place media funnel (part # U-1006) in hole on top of tank.
 - D. Pour several gallons of water in the tank. (Fill tank about 1/3 full.)
 - E. Pour in the required filter media. No gravel is required. The required quantity of media is listed in the filter specifications.

Note: If rebedding an existing unit and the system utilizes a standard tube & basket style distributor, a "D" gravel underbedding will be required.

- F. After filling the tank with material, use a garden hose or several buckets to fill the tank with water. This will permit the filtering media to become soaked while preparing the installation and will prevent the control valve from being plugged with floating material on initial backwash.
- G. Remove funnel and clean filter media from tank threads.
- H. Remove cap from distributor tube.
- I. Replace control valve on mineral tank. Do not use Teflon tape or paste on valve threads, as the valve to tank o-ring seals this joint.

Caution: Be extremely careful to position distributor tube into control valve distributor tube pilot hole.

3. Turn OFF main water supply and OPEN nearest faucet to relieve pressure.
4. Cut main line and install appropriate elbows and extensions. Inlet and outlet connections on the control valve are 3/4" FNPT. (1" FNPT for RF30 and RF40.)

Caution: Raised arrows located on the sides of control valve body and bypass valve indicate proper direction of water flow. Install inlet and outlet piping in direction of arrows. It is recommended that a vacuum breaker be installed on the inlet of the plumbing.

- Drain Line Connection -

1. The drain line flow control assembly is pre-assembled for your convenience. Should you choose to hard plumb the drain line, please remove the barb fitting. The flow control housing can be removed by removing the clip and pulling straight out on housing.

Note: When re-installing the drain line flow control housing, be sure you hear and feel the O-Ring pop into place before inserting the clip.

2. Install 1/2" I.D. drain line tubing (not included) from hose elbow to an open drain. A 4" gap between end of the drain line and the open drain is required to prevent waste water backflow. Keep the drain line as short as possible. An overhead drain line can be used if necessary, but should discharge below the control valve. A syphon trap (taped loop) at the outlet of the drain line is advisable to keep the drain line full and assure correct flow during backwash. Elbows or other fittings must be kept at a bare minimum.

Note: Where the drain line is elevated above the control valve or exceeds 20 feet in length, 3/4" I.D. drain line tubing should be used.

- Electrical Connection -

1. Connect the power supply to the control valve and plug into a 115 volt / 60 Hz receptacle.

Note: Do not plug into an outlet controlled by a wall switch or pull chain that could inadvertently be turned off.

Electronic Connections

P - Power Supply

**B - Powered in Backwash Step Only
(Cycle #1)**

S - Powered in Entire Regeneration Cycle



- Pressurizing The System -

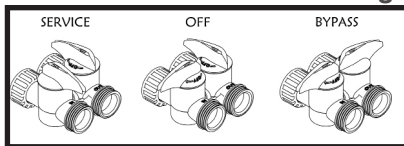

SIGNATURE 3 BYPASS - SHOWN

2. Slowly rotate handle of the bypass valve to the **SERVICE** position.
3. Open the nearest faucet to evacuate air from plumbing lines.
4. Check for leaks! If water is observed leaking from bypass, o-rings on valve body may not be seated properly. Exercise bypass valve.
5. After air is evacuated from plumbing lines, turn off faucet.

- Initial Control Valve Operation -

1. Advance control valve to BACKWASH (cycle 1) position and allow water to run to drain for 3 to 4 minutes.

Warning: Close handle on bypass prior to selecting the backwash position. After backwash position has been established, slightly open valve on bypass to evacuate air from the media tank. Fully open bypass valve when all air is depleted. This procedure will prevent media from being uplifted into control valve.

2. Advance control valve to RAPID RINSE (cycle 3) position and allow water to run to drain for 3 to 4 minutes.
3. Advance control valve to SERVICE (cycle 0) position.

- Final Checkout -

1. Be certain that the bypass valve is in Service position and main valve is completely on.
2. Check electrical supply to be certain the cord is connected to an uninterrupted 115 volt outlet.
3. Be certain to **REGISTER YOUR PRODUCT** online at www.csiwater.com
4. Leave this manual with the homeowner.

Important Notice - The plumbing system, piping, pressure tank, hot water tanks, softeners, etc. that have been exposed to iron bearing water may need to be cleaned of the precipitated iron that has been collected in them or iron bleed thru may be a problem. We suggest all tanks be drained and flushed thoroughly.

- Programming The Control Valve -

1. Set time of day.
2. Set a.m. or p.m.
3. Set number of days between backwash. (This generally will be every 4 to 6 days.)
4. Set regeneration time if other than 12:00 a.m. is desired.

Main Menu

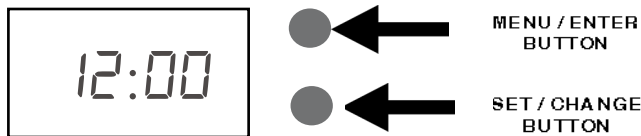

1. To enter Main Menu, press the **Menu/Enter** button.
(Time of Day will flash)
2. To set the **Time of Day**, press the **Set/Change** button.
(First digit will flash) Example [12:00]
 - To change digit value, press the **Set/Change** button.
 - To accept the digit value, press the **Menu/Enter** button.
 - Next digit will flash to begin setting.
 - Once the last digit display is accepted, all digits will flash.
3. To set **A.M.** or **P.M.**, press the **Menu/Enter** button. Example [A]
 - To change digit value, press the **Set/Change** button.
 - To accept the digit value, press the **Menu/Enter** button.
 - Once A.M. or P.M. is accepted, the next menu item will flash.
4. a. To set the **Number of Days between Backwash Cycles (A)**, press the **Set/Change** button. - Example [A - 06]
Repeat instructions from step (2).
Notes: 1) Maximum value is 29.
2) If value set to 0, Automatic Backwash will never occur.
3) Default setting is 6 days for filters.
5. To Exit Main Menu, press the **Menu/Enter** button.
Note: If no buttons are pressed for 60 seconds, the Main Menu will be exited automatically.

Normal Operation

1. Home Display



- a. Alternates between the display of Time of Day and Number of Days until the Next Backwash. (Metered Softeners will alternate between time of days and gallons remaining until next regeneration)
 - Days Remaining until the Next Backwash will count down from the entered value until it reaches 1 day remaining.
 - A Backwash Cycle will then be initiated at the next designated regeneration time.

2. Battery Back-Up (Uses a standard 9-volt alkaline battery.)

Features of Battery Back-Up:

- During power failures, the battery will maintain the time of day as long as the battery has power. The display is turned off to conserve battery power during this time. To confirm that the battery is working, press either button and the display will turn on for five (5) seconds.
- If power failure occurs while system is regenerating, the valve will motor to a shut off position to prevent constant flow to drain. Depending upon system pressure and other factors, it is possible to observe a reduced flow to drain during this step. After power is restored, the valve will return and finish the cycle where it left off prior to the power interruption.
- When used without battery back-up, during a power failure, the unit stops at its current point in the regeneration position and then restarts at that point when the power is restored. The time will be offset by the increment of time the unit was without power, so it is necessary to reset the time of day on the unit. No other system will be affected.

Starting Extra Regeneration Cycle

1. To Start **Delayed Extra Cycle** Example (1)
 If Days Remaining Until Next Backwash does not read '1', press and hold the **Set/Change** button for 3 seconds until the display reads '1'.
 - Backwash cycle will initiate at the next designated backwash time.
2. To start **Immediate Extra Cycle**  First complete above step.
 - With Days Remaining Until Next Regeneration at '1'.
 - Press and hold the **Set/Change** button.
 - After 3 seconds, the backwash cycle will begin.
3. To **Fast Cycle** thru regeneration  First complete above 2 steps.
Note: Press and hold the **Set/Change** button for 3 seconds to advance to the next cycle step. Fast Cycle is not necessary unless desired to manually step through each cycle step. (Repeat until valve returns to the home display)

Filters		Default (Min)
Step 1	Backwash	10
Step 2	Rest	20
Step 3	Rapid Rinse	16
Step 4	Not Used	0



For simplified set up and control, please install the Legacy View on a compatible Bluetooth 4.0+ enabled smart phone or tablet.

1. Download and install the Legacy View app from the Google Play Store, Apple App Store
2. Open the Legacy View app
 - Choose a valve device at any time from the list of available devices to connect to by clicking on it.
 - If the valve you want to connect to doesn't show up, or there is a problem connecting to a device you can press the "Scan for Devices" button or the Legacy View logo at any time to refresh the list and start the process over.
 - If the valve device is a BTLE valve and it has a password other than the default password, the first time you connect to it the app will ask you to enter the password. After entering it the first time you should not need to enter it again unless it changes.
3. BTLE Valve devices can be updated by the App. When the app is updated from the Google Play Store or the Apple App Store, it may contain an updated firmware program for the valve devices. These updates could contain new features or operational improvements. It is up to the user to allow these updates to be sent to the valve device. Uploading a new program takes approximately 1 minute.

Dashboard

NOTE: Consult your dealer before making any changes

From the Dashboard, all items in **ORANGE** can be changed, while blue fields are informational only.

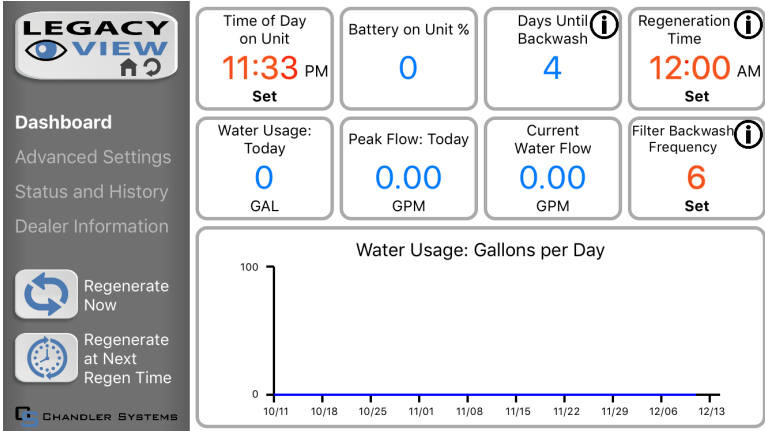

If you are unsure about the function of the field click the ⓘ for more information.

Utilizing Bluetooth Control

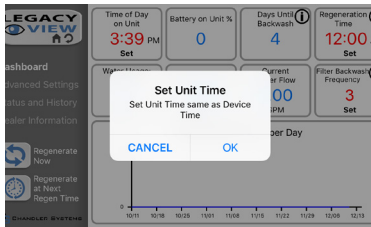

1. Change Time of day (Press “set” to set time automatically based on device time)



1. Set Backwash Frequency
This sets the amount of days between backwash cycles.

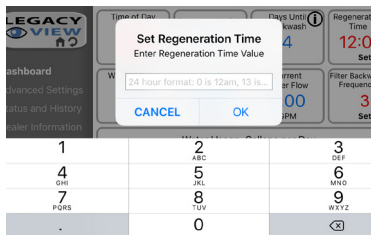

1. Set Regeneration Time
Example: For 2am, just type 2 and press OK.

Advanced Settings

NOTE: Consult your dealer before making any changes. We do not recommend changing Advanced Settings unless you have a good understanding of the system operation.

From the Advanced Settings, all items in **ORANGE** with a “set” button can be changed.

LEGACY VIEW

Dashboard
Advanced Settings
 Status and History
 Dealer Information

Regenerate Now
 Regenerate at Next Regen Time

CHANDLER SYSTEMS

Air Recharge Frequency
4
 Set

Cycle Position Times

Air Release **1** min.
 Backwash **10** min.
 Set
 Rest **5** min.
 Set
 Air Draw **20** min.
 Set

Rapid Rinse **5** min.
 Set

Status and History

From the Status and History, all items in **ORANGE** can be reset.

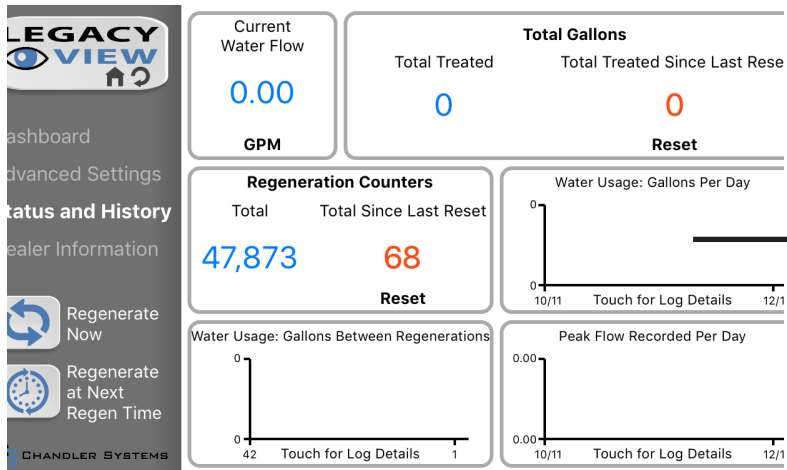

Touch any table to explode a detailed list of the last 60 days.

1. Start a regeneration or backwash cycle

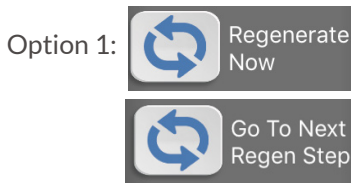

Click the “Regenerate Unit Now.”

If you would like to force the unit into the next cycle step click “Go to Next Regeneration Step”.



“Regenerate Unit at Next Regen Time” button.

This will take the system into a backwash cycle at the next regeneration time.



FCC ID: SWPLV-019 or SWPEV-019-BLE
 Name of Grantee: CHANDLER SYSTEMS, INC.
 Equipment Class: Part 15 Low Power Communication Device
 Notes: Legacy View Valve

This device complies with part 15 of the FCC Rules. Operation is subject to the following conditions: (1) this device may not cause harmful interference, and (2) this device must accept any interference received, including interference that may cause undesired operation. Changes or modifications not expressly approved by the party responsible for compliance could void the user’s authority to operate the equipment. NOTE: This equipment has been tested and found to comply with the limits for a Class B digital device, pursuant to Part 15 of the FCC Rules. These limits are designed to provide reasonable protection against harmful interference in a residential installation. This equipment generates, uses and can radiate radio frequency energy and, if not installed and used in accordance with the instructions, may cause harmful interference to radio communications. However, there is no guarantee that interference will not occur in a particular installation. If this equipment does cause harmful interference to radio or television reception, which can be determined by turning the equipment off and on, the user is encouraged to try to correct the interference by one or more of the following measures:

- Reorient or relocate the receiving antenna.
- Increase the separation between the equipment and receiver.
- Connect the equipment into an outlet on a circuit different from that to which the receiver is connected.
- Consult the dealer or an experienced radio/TV technician for help.

Master Programming Mode

To enter Master Programming Mode, press and hold both buttons for 5 seconds.

Note: All Master Programming functions have been preset at the factory. Unless a change is desired, it is **NOT** necessary to enter Master Programming Mode.

1. Regeneration Time (r)

Example [r 12A]

- The time of day at which backwash may take place is designated by the letter “r”.
- Default regeneration time settings is **12a**
- The first display digit indicates A.M. or P.M. To change the value, press the **Set/Change** button.
- Press **Menu/Enter** button to accept the value and move to the next digit.
- The second and third display digits indicate the hour at which the backwash will occur.
- Change the digits with the **Set/Change** button and accept with the **Menu/Enter** button.
- After the entire display flashes, press the **Menu/Enter** button to move to the next menu item.

2. Regeneration Cycle Step Times (Steps 1, 2, 3)

Example [3 - 10]

- The next 4 displays set the duration of time in minutes for each backwash cycle step.
- The step number which is currently modifiable is indicated on the far left of the display screen.
- The number of minutes allotted for the selected backwash step is displayed on the far right.
- Change the digit values using the **Set/Change** and **Menu/Enter** buttons as described above.

3. Bluetooth Enabled

bE - 1 (ON)

bE - 0 (OFF)

4. Bluetooth Password

BBPP is displayed for one second, then password is displayed.

5. To Exit the Master Programming Mode, press the **Menu/Enter** button until time of day returns.

Note: If no buttons are pressed for 60 seconds, the Master Programming Mode will be exited automatically.

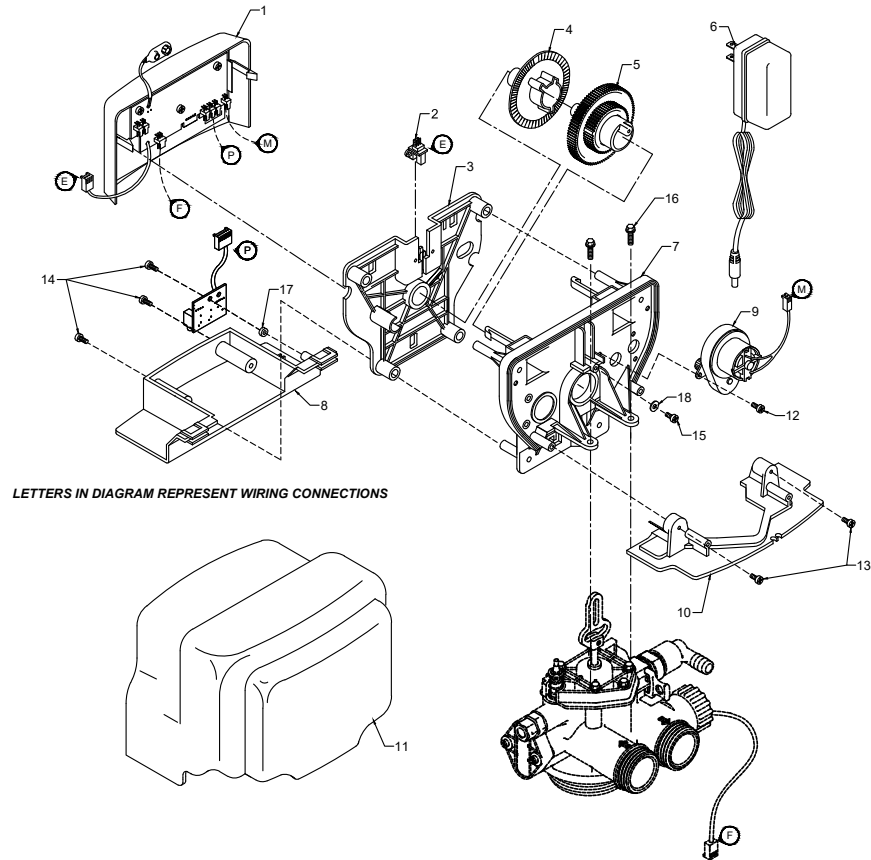

REF	DESCRIPTION	PART NO	QTY
0	Reactr™ Power Head Assy.	21005X100	1
1	Reactr™ Circuit Board Assy.	22005X102	1
2	Encoder	20001X124	1
3	Front Plate	20001X004	1
4	Encoder Wheel	20001X007	1
5	Main Gear	21001X120	1
6	Power Supply	20001X125	1
7	Back Plate	20001X005	1
8	Lower Front Base For Cover	20111X002	1
9	Motor	20016X006	1
10	Lower Back Base for Cover	20111X003	1
11	Valve Cover	20111X000	1
12	Piston Screw	20001X003	1
13	Screw	SC10	3
14	Screw	SC9	2
15	Piston Washer	20001X002	1
16	Washer Circuit Board	20111X014	1
17	Screw Motor	SC2	1
21	Valve Hex Screw	20001X001	2

Manifold - SIGNATURE 3

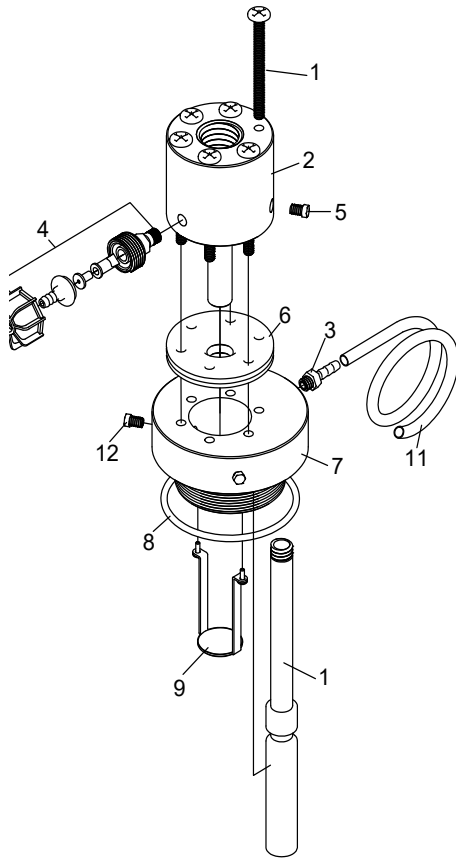

REF	DESCRIPTION	PART NO	QTY
0	Complete Manifold Assy w/ Float	65555X330	1
1	Screw: 1/4" X 3-1/2" SS Phillips	65555X221	6
2	Body with Nozzle & Throat	65555X205	1
3	Hose Barb: 1/4 x 1/4" NPT	69000B110	1
4	Air Inlet Check Valve Assembly	65555X250	1
5	1/8" Plastic Pipe Plug	65555X213	1
6	Diaphragm	65555X219	2
7	Manifold with O-Ring	65555X208	1
8	Manifold O-Ring Only	20561X205	1
9	Diffuser with Screws	65555X212	1
10	Float Assembly	65555X210	1
11	3/8" OD X 1/4" ID X 12 Ft Vent Tubing	65555X216	1
12	1/4" Plastic Pipe Plug	65555X230	2

Valve Body Assembly - SIGNATURE 3

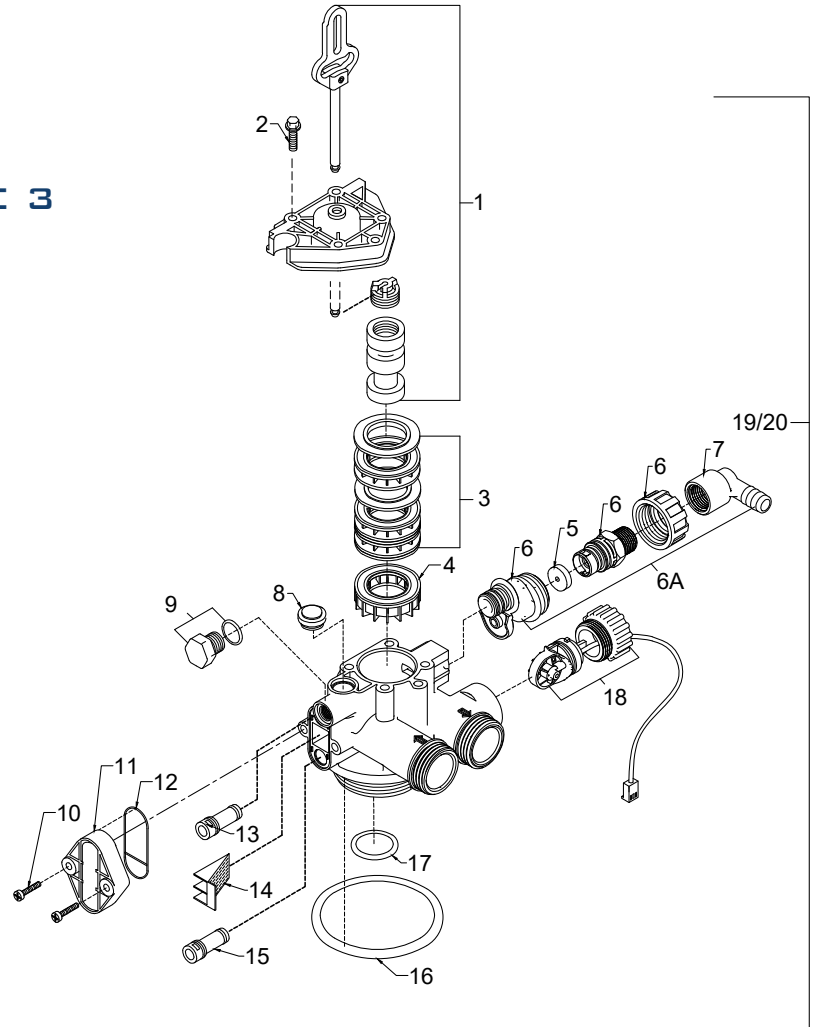

REF	DESCRIPTION	PART NO.	QTY
1	Piston Assembly	20001X231	1
2	10-24 X 3/4" Screw SST	20001X001	3
3	Seal and Spacer Kit Incl (5) #3 & (4) #4	20561X253	1
4	End Spacer	20001X234	1
5	Flow Control Button 5.0 GPM	20251X272	1
	Flow Control Button 7.0 GPM	20251X273	1
6A	DLFC Assy.	20017X251	1
7	90 Degree Hose Barb Elbow	20017X266	1
8	Brine Valve Plug w/ O-Ring	20001X230	1
9	Filter Plug Assy. w/ O-Ring	20001X229	1
10	10-24 X 3/4" Screw SST	20001X001	2
11	Injector Cap	20001X223	1
12	Injector Seal	20001X224	1
13	Injector Plug & O-Ring Assy.	20001X217	1
14	Injector Screen	20001x222	1
15	Injector Plug & O-Ring Assy.	20001X217	1
16	Valve O-Ring	20015X043	1
17	Dist. O-Ring	20561X204	1
18	Meter Assembly	20017X203	1

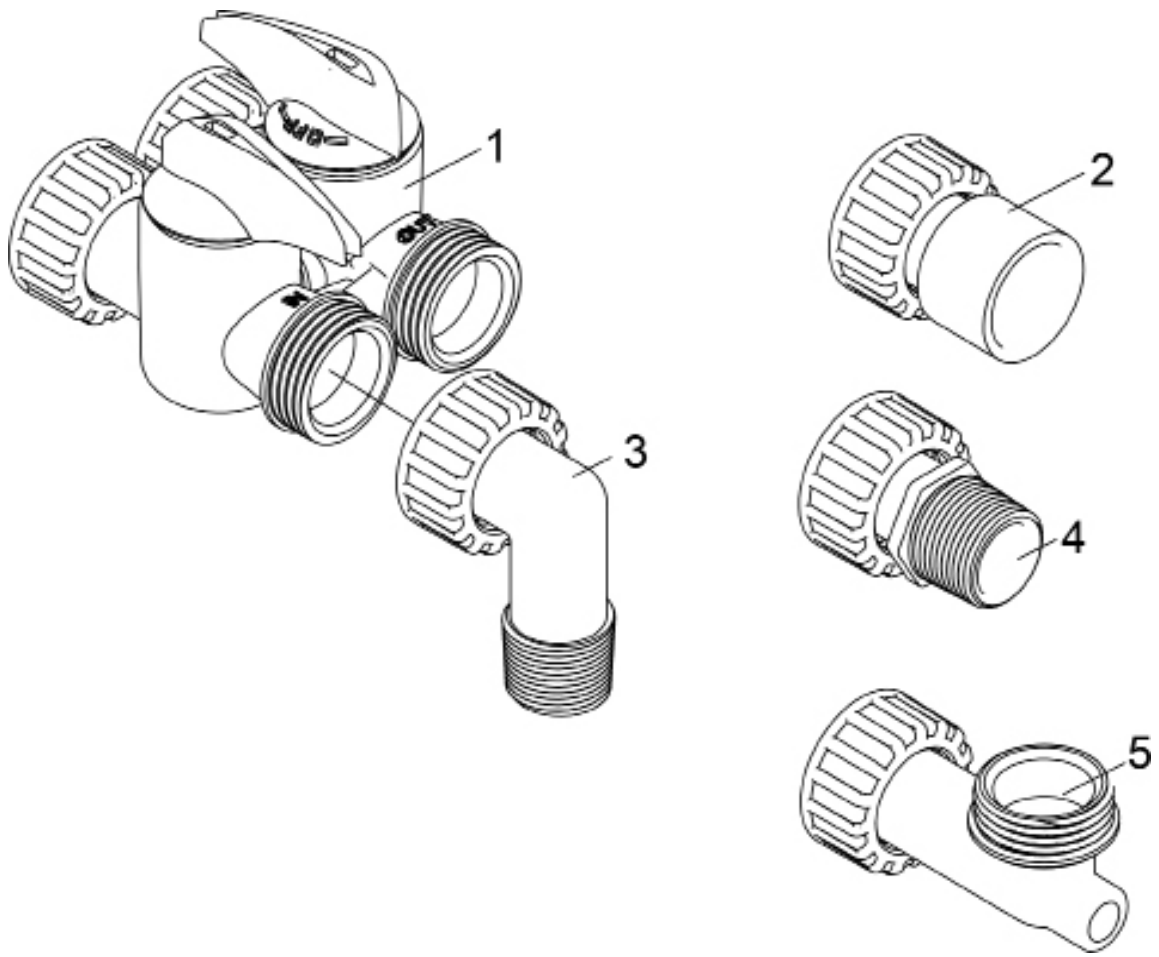

REF	DESCRIPTION	PART NO
1	D15 Bypass	20017X283
2	1" Female Straight Slip Set (optional)	20017X288
3	1" NPT Elbow Set	20017X284
4	1" NPT Straight Set (optional)	20017X289
5a	Elbow, Vertical Adapter Blank (optional)	20017X295
5b	Elbow, Vertical Adapter 1/4" NPT Tapped (optional)	20017X294

A. General Preliminary Instructions

PERFORM BEFORE ALL SERVICING OPERATIONS

1. Turn off water supply to conditioner.
 - If the conditioner installation has a “three valve” bypass system, first open the valve in the bypass line, then close the valves at the conditioner inlet and outlet.
 - If the conditioner has an integral bypass valve, put it in the bypass position.
 - If there is only a shut off valve near the conditioner inlet, close it.
2. Remove cover and relieve water pressure in the conditioner by stepping the control into the backwash position momentarily. Return the control to the service position.
3. Unplug electrical cord from outlet.

B. To Replace Powerhead

1. Remove the control valve cover and disconnect the power supply.
2. Disconnect the meter cable from circuit board and feed back through control (if existing meter is being re-used)
3. Remove lower back base screws and detach lower back base.
4. Remove screw and washer at drive yoke. Remove powerhead mounting screws. The entire powerhead assembly will now lift off easily.
5. Put new powerhead on top of the valve. Be sure the drive pin on main gear engages slot in drive yoke (wide side of drive yoke upright must face to the left away from the motor).
6. Replace powerhead mounting screws. Replace screw and washer at drive yoke.
7. Reattach lower back base.
7. Reconnect meter signal, wire and power supply.
8. Reinstall cover.

C. To Replace Piston Assembly

1. Follow steps **A1 - A3**
2. Disconnect the meter signal wire from the circuit board.
3. Remove lower back base screws and detach lower back base.
4. Remove screw and washer at piston drive yoke. Remove powerhead mounting screws. The entire power head assembly will now lift off easily.
5. Remove piston retaining plate screws.
6. Pull upward on end of piston yoke until assembly is out of valve.
7. Inspect the inside of the valve to make sure that there is no foreign matter that would interfere with the valve operation.
8. Install new seals and spacers.
9. Take new piston assembly and push piston into valve by means of the end plug. Twist drive yoke carefully in a clockwise direction to properly align it with drive gear. Reinstall piston retaining plate screws.
10. Follow steps **B5 - B9**

D. To Replace Seals and Spacers

1. Follow steps **A1 - A3**.
2. Disconnect the meter signal wire from the circuit board.
3. Remove screw and washer at piston drive yoke. Remove powerhead mounting screws. The entire power head assembly will now lift off easily. Remove piston retaining plate screws.
4. Pull upward on end of piston rod yoke until assembly is out of valve. Remove seals and spacers.
(**Note:** Special end spacer must be reused)
5. Lubricate new seals with silicone lubricant included in the seal and spacer kit. Make sure the special end spacer is properly seated in the valve body. Install new seals and spacers individually, pressing around the outer edge of each seal to make sure it is seated. (When all seals and spacers are seated properly, you will have a 1/4” of space between the top seal the the top of the valve body)
6. Follow Steps **C9 - C10**.

SYMPTOM	PROBABLE CAUSE	CORRECTION
1. Reactr Fails to Regenerate Automatically	Power supply plugged into intermittent or dead power source	Connect to constant power source
	Improper control valve programming	Reset program settings
	Defective power supply	Replace power supply
	Defective Drive motor	Replace motor
2. Regeneration at Wrong Time	Time of day improperly set, due to power failure	Reset time of day programming and install 9-volt battery.
	Regeneration time set improperly	Reset regeneration time programming
3. Poor Water Quality	Check items listed in #1 and #2	
	Bypass valve open	Close bypass valve.
	Channeling	Check for too slow or high service flow. Check for media fouling.
	Water is not getting enough aeration	Check for air draw at air inlet check valve while well pump is running. Clean air inlet check valve, reactr nozzle and float assembly.
4. Loss of Water Pressure	Scaling / fouling of inlet pipe	Clean or replace pipline. Pretreat to prevent.
	Fouled media	Clean media. Pretreat to prevent.
	Improper backwash setting	Backwash more frequently
5. Continuous Flow to Drain	Foreign material in control valve	Call dealer. Clean valve and replace piston and seals
	Internal control leak	Same as above.
	Valve jammed in backwash, brine or rapid rinse position	Same as above.
	Motor stopped or jammed	Check for jammed piston. Replace piston and seals. Replace motor if motor is unresponsive.

Service Instructions / Instructional Videos Available at www.csiwater.com

Control Valve Error Code Diagnosis

Under normal operating conditions, when your control valve is in the “in service” position, the display should alternate between the current time of day and the number of days remaining (for filters and time clock softeners) or gallons remaining (for metered softeners) until the next regeneration. This is the “home display.” If the valve is currently going through a regeneration cycle, the display will show the cycle step on the left side of the display and the number of minutes remaining in that step on the right side of the display. If any other information is being displayed, then the valve is informing you of an issue. There are five error codes which could indicate an issue with the control valve. When an error is being displayed, the valve will be in a stopped position, and the buttons will not respond to being pressed. Even if the cause of the error code is corrected, the error code will not clear until the power supply has been disconnected and reconnected (this will be referred to as “cycling” the power). All error codes are displayed as the letters “Err” followed by a flashing number 2-6:

Error 2 - Valve is searching for homing slot.

Allow valve to continue running. If the homing slot is found, the valve will return to the home display, otherwise, another error code will appear.

Error 3 - No encoder slots are being seen.

This occurs when the motor is running, but the encoder is not seeing any of the slots in the encoder wheel. This can happen if the encoder has been disconnected, but most commonly occurs when debris in the valve body has stopped the piston, causing the encoder wheel to be unable to turn.

1. Check encoder connection. If the encoder is plugged in and snapped into place, skip to step #2 below. If encoder is disconnected, reconnect it and cycle power to clear the error.
2. Disconnect powerhead from valve body, cycle power to clear the error code. Manually cycle the power head through the regeneration cycle steps to verify that the motor can cycle properly while the power head is disconnected from the valve body. If the error 3 does not reappear, skip to step #3 below. If the error 3 does reappear, order a board & motor kit to replace the circuit board & motor.
3. Remove piston and seals from the valve body and inspect valve body for debris. Replace the seal & spacer kit. Inspect piston and replace piston if Teflon coating is worn

Error 4 - Unable to find homing slot.

1. Check encoder wheel for debris.
2. Cycle power. Valve should either find home or go to a different error code. If error 4 returns, replace powerhead assembly.

Error 5 - Motor overload.

This occurs when the motor current is too high. This could be caused by an issue with the motor itself, but is typically caused by friction in the valve body

1. Disconnect powerhead from valve body and cycle power to clear the error code.
2. If the error 5 returns, replace the motor. Otherwise, manually cycle the powerhead through the regeneration cycle steps to verify that the motor can cycle properly while the powerhead is disconnected from the valve body. Either way, proceed to the next step.
3. Remove piston and seals from the valve body and inspect valve body for debris. Replace the seal & spacer kit. Inspect piston and replace piston if Teflon coating is worn.

Error 6 - No motor current.

This typically occurs if the motor cable has come unplugged from the circuit board. Check that the motor cable is plugged into the circuit board and attached to the motor. If this is not the issue, the motor or circuit board may need to be replaced.

No Display

If your display is blank, there is no power going to the circuit board due to one of the following factors:

- The electrical outlet is not powered or is switched off
- The power cable has come unplugged from the circuit board
- The power supply has come unplugged from your electrical outlet
- The power supply has come unplugged from the control valve
- The power supply is not working

Warranty

WATER TREATMENT EQUIPMENT

This warranty cannot be transferred - it is extended only to the original purchaser or first user of the product. By accepting and keeping this product, you agree to all of the warranty terms and limitations of liability described below.

Important Warning: Read carefully the CSI Water Treatment Systems Equipment Installation, Operating and Maintenance Instructions Manual to avoid serious personal injury and property HAZARDS and to ensure safe and proper care of this product.

Model Numbers Covered:
Water Softeners, Media Filters and Upflow Filters

*FOR AS LONG AS YOU OWN AND LIVE IN YOUR SINGLE FAMILY HOME, this warranty covers your water treatment equipment, if you are the first user of this CSI Water Treatment Systems equipment and purchased it for single family home use - subject to all of the conditions, limitations and exclusions listed below. Purchasers who buy the CSI Water Treatment Systems equipment for other purposes, and other component parts are subject to more limited warranties and you should read all of the terms included in this form to make sure you understand your warranty.

What is covered by this warranty?
CSI Water Treatment Systems warrants that at the time of manufacture, the water treatment equipment shall be free from defects in material and workmanship as follows :

Product	Warranty
Residential Mineral Tank	10 Years
Proprietary Control Valves	7 Years
Other Softener / Filter Control Valves	5 Years
Brine Tank	5 Years
Residential Reverse Osmosis System	5 Years
Other Accessories and Parts	1 Year
Brine Tank Components	1 Year

* This warranty does not include media and/or cartridge filter elements.

Additional Terms & Conditions
What CSI Water Treatment Systems will do if you have a covered warranty claim CSI will at its option either make repairs to correct any defect in material or workmanship or supply and ship either new or used replacement parts or products. CSI will not accept any claims for labor or other costs.

Additional Exclusions and Limitations
This warranty is non-transferable and does not cover any failure or problem unless it was caused solely by a defect in material or workmanship. In addition, this warranty shall not apply :

- If the water treatment equipment is not correctly installed, operated, repaired and maintained as described in the Installation, Operating & Maintenance Instructions Manual provided with the product.
- To any failure or malfunction resulting from abuse (including freezing), improper or negligent handling, shipping (by anyone)
- Defects caused as a direct result of the incoming water quality

- If the tank is not the size indicated for the supply line size of the installation, as described in the manual. •
If the unit has not always been operated within the factory calibrated temperature limits, and at a water pressure not exceeding 125 psi other than CSI), storage, use, operation, accident; or alteration, lightning, flooding or other environmental conditions;
- To any failure or malfunction resulting from failure to keep the unit full of potable water, free to circulate at all times; and with the tank free of damaging water sediment or scale deposits;
- This warranty does not cover labor costs, shipping charges, service charges, delivery expenses, property damage, administrative fees or any costs incurred by the purchaser in removing or reinstalling the water treatment equipment.
- The warranty does not cover any claims submitted to CSI more than 30 days after expiration of the applicable warranty, and does not apply unless prompt notice of any claim is given to an authorized CSI Dealer or to CSI or a designated contractor is provided access to the installation and to the water treatment equipment.

THESE WARRANTIES ARE GIVEN IN LIEU OF ALL OTHER EXPRESS WARRANTIES. NO CSI REPRESENTATIVE OR ANY OTHER PARTY IS AUTHORIZED TO MAKE ANY WARRANTY OTHER THAN THOSE EXPRESSLY CONTAINED IN THIS WARRANTY AGREEMENT.

Additional Warranty Limitations
ANY IMPLIED WARRANTIES THE PURCHASER MAY HAVE, INCLUDING THE IMPLIED WARRANTIES OF MERCHANTABILITY AND FITNESS FOR A PARTICULAR PURPOSE, SHALL NOT EXTEND BEYOND THE APPLICABLE TIME PERIODS SPECIFIED ABOVE. Some states do not allow limitations on how long an implied warranty lasts, so the above limitations may not apply to you.

Limitations of Remedies
The remedies contained in this warranty are the purchaser's exclusive remedies. In no circumstances will CSI or the seller of the product be liable for more than, and purchaser-user's remedies shall not exceed, the price paid for the product. In no case shall CSI or seller be liable for any special, incidental, contingent or consequential damages. Special, incidental, contingent and consequential damages for which CSI is not liable include, but are not limited to, inconvenience, loss or damage to property, consequential mold damage, loss of profits, loss of savings or revenue, loss of use of the products or any associated equipment, facilities, buildings or services, downtime, and the claims of third parties including customers. Some states do not allow the exclusion or the limitation of incidental or consequential damages, so the above limitations or exclusion may not apply to you.

What to do if you have a problem covered by this warranty
Any warranty coverage must be authorized by CSI. Contact the person from whom you purchased the product, who must receive authorization from a CSI Dealer .

If your product is new and not used and you wish to return it, contact your CSI Dealer.

CSI WATER TREATMENT SYSTEMS